





### General Precautions

Read this entire manual and all other publications pertaining to the work to be performed before installing, operating, or servicing this equipment.

Practice all plant and safety instructions and precautions.

Failure to follow instructions can cause personal injury and/or property damage.



### Revisions

This publication may have been revised or updated since this copy was produced. To verify that you have the latest revision, check manual **26455**, *Customer Publication Cross Reference and Revision Status & Distribution Restrictions*, on the *publications* page of the Woodward website:

[www.woodward.com/publications](http://www.woodward.com/publications)

The latest version of most publications is available on the *publications* page. If your publication is not there, please contact your customer service representative to get the latest copy.



### Proper Use

Any unauthorized modifications to or use of this equipment outside its specified mechanical, electrical, or other operating limits may cause personal injury and/or property damage, including damage to the equipment. Any such unauthorized modifications: (i) constitute "misuse" and/or "negligence" within the meaning of the product warranty thereby excluding warranty coverage for any resulting damage, and (ii) invalidate product certifications or listings.



### Translated Publications

If the cover of this publication states "Translation of the Original Instructions" please note:

The original source of this publication may have been updated since this translation was made. Be sure to check manual **26455**, *Customer Publication Cross Reference and Revision Status & Distribution Restrictions*, to verify whether this translation is up to date. Out-of-date translations are marked with . Always compare with the original for technical specifications and for proper and safe installation and operation procedures.

**Revisions**—Changes in this publication since the last revision are indicated by a black line alongside the text.

Woodward reserves the right to update any portion of this publication at any time. Information provided by Woodward is believed to be correct and reliable. However, no responsibility is assumed by Woodward unless otherwise expressly undertaken.

# Contents

<b>WARNINGS AND NOTICES</b> .....	<b>3</b>
<b>ELECTROSTATIC DISCHARGE AWARENESS</b> .....	<b>4</b>
<b>REGULATORY COMPLIANCE</b> .....	<b>5</b>
<b>CONTROL SPECIFICATIONS</b> .....	<b>6</b>
<b>CHAPTER 1. GENERAL INFORMATION</b> .....	<b>7</b>
Description .....	7
Applications .....	7
References .....	8
2301A Load Sharing and Speed Control Models, 9905/9907 Series .....	9
<b>CHAPTER 2. INSTALLATION</b> .....	<b>13</b>
Unpacking .....	13
Power Requirements .....	13
Location Considerations .....	13
Electrical Connections .....	13
Shielded Wiring .....	14
Setting Speed Range .....	14
Potential Transformer Connections .....	15
Current Transformer Connections .....	15
Droop Contact (Isoch-Droop) and Load Sharing Lines .....	16
Power Supply .....	17
Minimum Fuel Contact.....	17
Failed Speed Signal Override .....	17
Idle/Rated Ramp Contact .....	18
Actuator Output .....	18
External Speed Trim .....	18
Speed and Phase Matching (SPM) Synchronizer .....	18
Speed Sensor .....	18
Installation Check-out Procedure .....	19
<b>CHAPTER 3. OPERATION AND ADJUSTMENT</b> .....	<b>20</b>
Initial Pre-Start Settings .....	20
Start-Up Adjustments .....	20
Adjust For Stable Operation .....	22
Speed Setting Adjustment .....	22
Dynamic Adjustment .....	22
Actuator Compensation Adjustment .....	23
Low Idle Speed Adjustment .....	23
Ramp Time Adjustment .....	23
Start Fuel Limit Adjustment .....	25
Speed Sensor Check.....	25
Current Transformer (CT) Phasing Check .....	25
Phase Correction Procedure .....	26
Load Gain Adjustment .....	29
Droop Adjustment .....	30
<b>CHAPTER 4. DESCRIPTION OF OPERATION</b> .....	<b>32</b>
Introduction .....	32
Speed Control.....	32
Terminals for External Devices .....	34
Paralleling .....	34

# Contents

<b>CHAPTER 5. TROUBLESHOOTING .....</b>	<b>37</b>
Troubleshooting Procedure .....	37
<b>CHAPTER 6. PRODUCT SUPPORT AND SERVICE OPTIONS.....</b>	<b>43</b>
Product Support Options .....	43
Product Service Options .....	43
Returning Equipment for Repair .....	44
Replacement Parts .....	44
Engineering Services.....	45
Contacting Woodward's Support Organization .....	45
Technical Assistance .....	46
<b>REVISION HISTORY .....</b>	<b>47</b>
<b>DECLARATIONS .....</b>	<b>48</b>

## Illustrations and Tables

Figure 1-1. 2301A Control Outline Drawing .....	10
Figure 1-2a. Plant Wiring Diagram (low-voltage supply) .....	11
Figure 1-2b. Plant Wiring Diagram (high-voltage supply).....	12
Figure 2-1. Preparation and Installation of Shielded Cables .....	14
Figure 2-2. Switch S1 .....	15
Figure 2-3. Droop Contact and Circuit Breaker Auxiliary Contact.....	16
Figure 3-1. Diesel Engine Performance Curves.....	24
Figure 3-2. Temporary Wiring for Transformer Phase Correction.....	27
Figure 3-3. Droop Adjustment .....	30
Figure 3-4. 3% Droop at 60 Hz.....	31
Figure 4-1. Speed Control System .....	32
Figure 4-2. Speed Control Adjustments .....	33
Figure 4-3. Terminal Connections .....	35
Figure 4-4. Paralleling System .....	36
Figure 4-5. Paralleling Adjustments.....	36
Table 1-1. Low-Voltage 2301A Models (20 to 40 Vdc) .....	9
Table 1-2. High-Voltage 2301A Models (88–132 Vac or 90–150 Vdc) .....	9
Table 6-1. Troubleshooting.....	37

# Warnings and Notices

## Important Definitions



This is the safety alert symbol. It is used to alert you to potential personal injury hazards. Obey all safety messages that follow this symbol to avoid possible injury or death.

- **DANGER**—Indicates a hazardous situation which, if not avoided, will result in death or serious injury.
- **WARNING**—Indicates a hazardous situation which, if not avoided, could result in death or serious injury.
- **CAUTION**—Indicates a hazardous situation which, if not avoided, could result in minor or moderate injury.
- **NOTICE**—Indicates a hazard that could result in property damage only (including damage to the control).
- **IMPORTANT**—Designates an operating tip or maintenance suggestion.

### **WARNING**

#### Overspeed / Overtemperature / Overpressure

The engine, turbine, or other type of prime mover should be equipped with an overspeed shutdown device to protect against runaway or damage to the prime mover with possible personal injury, loss of life, or property damage.

The overspeed shutdown device must be totally independent of the prime mover control system. An overtemperature or overpressure shutdown device may also be needed for safety, as appropriate.

### **WARNING**

#### Personal Protective Equipment

The products described in this publication may present risks that could lead to personal injury, loss of life, or property damage. Always wear the appropriate personal protective equipment (PPE) for the job at hand. Equipment that should be considered includes but is not limited to:

- Eye Protection
- Hearing Protection
- Hard Hat
- Gloves
- Safety Boots
- Respirator

Always read the proper Material Safety Data Sheet (MSDS) for any working fluid(s) and comply with recommended safety equipment.

### **WARNING**

#### Start-up

Be prepared to make an emergency shutdown when starting the engine, turbine, or other type of prime mover, to protect against runaway or overspeed with possible personal injury, loss of life, or property damage.

### **WARNING**

#### Automotive Applications

On- and off-highway Mobile Applications: Unless Woodward's control functions as the supervisory control, customer should install a system totally independent of the prime mover control system that monitors for supervisory control of engine (and takes appropriate action if supervisory control is lost) to protect against loss of engine control with possible personal injury, loss of life, or property damage.

**NOTICE****Battery Charging  
Device**

To prevent damage to a control system that uses an alternator or battery-charging device, make sure the charging device is turned off before disconnecting the battery from the system.

## Electrostatic Discharge Awareness

**NOTICE****Electrostatic  
Precautions**

Electronic controls contain static-sensitive parts. Observe the following precautions to prevent damage to these parts:

- Discharge body static before handling the control (with power to the control turned off, contact a grounded surface and maintain contact while handling the control).
- Avoid all plastic, vinyl, and Styrofoam (except antistatic versions) around printed circuit boards.
- Do not touch the components or conductors on a printed circuit board with your hands or with conductive devices.

To prevent damage to electronic components caused by improper handling, read and observe the precautions in Woodward manual **82715**, *Guide for Handling and Protection of Electronic Controls, Printed Circuit Boards, and Modules*.

Follow these precautions when working with or near the control.

1. Avoid the build-up of static electricity on your body by not wearing clothing made of synthetic materials. Wear cotton or cotton-blend materials as much as possible because these do not store static electric charges as much as synthetics.
2. Do not remove the printed circuit board (PCB) from the control cabinet unless absolutely necessary. If you must remove the PCB from the control cabinet, follow these precautions:
  - Do not touch any part of the PCB except the edges.
  - Do not touch the electrical conductors, the connectors, or the components with conductive devices or with your hands.
  - When replacing a PCB, keep the new PCB in the plastic antistatic protective bag it comes in until you are ready to install it. Immediately after removing the old PCB from the control cabinet, place it in the antistatic protective bag.

# Regulatory Compliance

## European Compliance for CE Mark

These listings are limited only to those units bearing the CE Marking.

<b>Low Voltage Directive:</b>	Directive 2014/35/EU on the harmonisation of the laws of the Member States relating to the making available on the market of electrical equipment designed for use within certain voltage limits
<b>EMC Directive:</b>	Declared to Directive 2014/30/EU of the European Parliament and of the Council of 26 February 2014 on the harmonization of the laws of the Member States relating to electromagnetic compatibility (EMC)

## North American Compliance

**CSA:** CSA Certified for Ordinary Locations for use in the United States and Canada.

# Control Specifications

## General Specifications

Power Supply Rating	90–150 Vdc or 85–132 Vac for High Voltage models
Power Consumption	20–40 Vdc for Low Voltage models less than or equal to 15 W nominal
<b>Inputs—</b>	
Load Sensing	90–240 Vac 3 $\emptyset$ 45–66 Hz 3 $\emptyset$ current transformer input
Speed Sensor Input Impedance	100–300 $\Omega$
Speed Sensor	magnetic pickup 1.0 Vac minimum to 30 Vac maximum
Speed Trim	0–100 $\Omega$ for 0 to 10% speed change
Speed Setting	terminals 23–24 jumpered, internally adjustable 100 $\Omega$ potentiometer allows external 0–10% speed trim
Idle Speed Select	external switch, open terminals 19 to 16
Drrop	external switch, open terminals 14 to 16
Synchronizer	$\pm 5$ Vdc for speed change with Woodward SPM-A synchronizer
Load Sharing	0–6 Vdc
<b>Outputs—</b>	
Actuator	7.5 Vdc max for 0 to 214 mA with 35 $\Omega$ coil
<b>Adjustments—</b>	
Rated Speed	11 450 Hz
Acceleration Ramp ( $\pm$ Idle to Rated)	0–10 s, switch activated, close terminals 19 to 16
Actuator Compensation	time constant compatibility 0–500 ms
Low Idle Speed	55% rated
Load Gain	6 Vdc maximum at 5 A CT current
Drrop	0 to 10%
Speed Control Range	switch selectable, 500–1500 Hz, 1000–3000 Hz, 2000–6000 Hz (standard), 4000–12 000 Hz
Operating Temperature	–40 to +85 $^{\circ}$ C (–40 to +185 $^{\circ}$ F)
Load Sharing	$\pm 5\%$ of rated load with speed setting matched
Vibration	4 Gs, 5 to 500 Hz
Shock	60 Gs
Weight	approximately 1.8 kg (4 lb)
Finish	gloss powder

# Chapter 1.

## General Information

### Description

The 9905/9907 series of the Woodward 2301A controls load sharing and speed of generators driven by diesel or gasoline engines, or steam or gas turbines. These power sources are referred to as “prime movers” throughout this manual.

The control is housed in a sheet-metal chassis and consists of a single printed circuit board. All potentiometers are accessible from the front of the chassis.

The 2301A provides control in either isochronous or droop mode.

The isochronous mode is used for constant prime mover speed with:

- Single-prime-mover operation;
- Two or more prime movers controlled by Woodward load sharing control systems on an isolated bus;
- Base loading against an infinite bus with the load controlled by an Automatic Power Transfer and Load (APTL) Control, an Import/Export Control, a Generator Loading Control, a Process Control, or another load-controlling accessory.

The droop mode is used for speed control as a function of load with:

- Single-prime-mover operation on an infinite bus or
- Parallel operation of two or more prime movers.

The following is an example of the typical hardware needed for the 2301A system controlling a single prime-mover and generator:

- A 2301A electronic control
- An external 20 to 40 Vdc power source for low-voltage models; 90 to 150 Vdc or 88 to 132 Vac for high-voltage models
- A proportional actuator to position the fuel-metering device, and
- Current and potential transformers for measuring the load carried by the generator.

### Applications

The 2301A 9905/9907 series electronic controls have switch-selectable speed ranges. Any of these control models can be set to operate within one of the following rated speed ranges:

- 500 to 1500 Hz
- 1000 to 3000 Hz
- 2000 to 6000 Hz
- 4000 to 12 000 Hz

#### **WARNING**

The speed range is factory set for 2000 to 6000 Hz. Refer to the inside cover to change speed range and prevent possible overspeed. Using the wrong speed range could cause an overspeed with resulting damage to equipment and/or personal injury or death.

#### **NOTICE**

The Rated Speed potentiometer is the only multi-turn pot in this control. All other pots are single-turn. Take care not to turn these pots beyond their stops.

These controls are available for forward- or reverse-acting applications, and for use with either single or tandem actuators. Models for three different actuator current ranges are available, as well as a high-voltage model (90 to 150 Vdc or 88 to 132 Vac, 45 to 440 Hz), and a low-voltage model (20 to 40 Vdc). The high voltage model is identified as such on the front; the low voltage model is not.

In reverse-acting systems, the actuator calls for more fuel when the actuator voltage decreases. Complete loss of voltage to the actuator will drive the actuator to full fuel. This allows a backup mechanical ballhead governor to take control rather than shut down the prime mover as would a direct-acting system.

An optional deceleration ramp is also offered. When this option is present, the time to ramp from rated speed to idle speed is approximately 20 seconds. If this option is not present, this happens instantly.

Tables 1-1 and 1-2 show part numbers and features of all 9905/9907 series 2301A load sharing and speed controls.

## IMPORTANT

**External wiring connections for reverse-acting controls are identical to those for direct-acting controls.**

The relationship between prime mover speed and sensor output frequency is expressed in the formula:

***Sensor Frequency in Hz equals the number of teeth on the speed sensing gear times the rated prime mover speed in revolutions per minute divided by 60.***

Application engineers from Woodward or any of its authorized distributors or agents are always available to assist you in selection of the correct control for your system, or to answer questions concerning control installation, operation, or calibration. See Chapter 6 for contact information.

## References

The following publications contain additional product or installation information on Load Sharing and Speed Controls, and related components. They are available on the Woodward website ([www.woodward.com/ic](http://www.woodward.com/ic)).

### technical

manual	title
25070	<i>Electronic Governor Installation Guide</i>
26260	<i>Governing Fundamentals and Power Management</i>
82384	<i>SPM-A Synchronizer 9905-002</i>
82510	<i>Magnetic Pickups &amp; Proximity Switches for Electronic Controls</i>
82715	<i>Guide for Handling and Protection of Electronic Controls, Printed Circuit Boards, and Modules</i>

### product

specification	title
82383	<i>SPM-A Synchronizer</i>
82390	<i>2301A Load Sharing and Speed Controls (9905 Series)</i>
82516	<i>EG3P/6P/10P Actuator</i>
82575	<i>EGB1P/2P Governor/Actuator</i>

## 2301A Load Sharing and Speed Control Models, 9905/9907 Series

Table 1-1. Low-Voltage 2301A Models (20 to 40 Vdc)

Part Number	Actuator Current (mA)	Forward/Reverse Acting	Actuator Tandem/Single	Decel Ramp
9905-020	0–200	Forward	Single	No
9905-021	0–200	Reverse	Single	No
9905-022	0–400	Forward	Single	No
9905-023	0–400	Reverse	Single	No
9905-024	0–200	Forward	Tandem	No
9905-025	0–200	Reverse	Tandem	No
9905-026	0–20	Forward	Single	No
9905-027	0–20	Reverse	Single	No
9905-028	0–200	Forward	Single	Yes
9905-029	0–200	Reverse	Single	Yes
9907-018 *	0–200	Forward	Single	No
9907-019 *	0–200	Reverse	Single	No
9907-023 *	0–200	Forward	Single	No
9907-024 *	0–200	Reverse	Single	No

\*—CE Approved models

Table 1-2. High-Voltage 2301A Models (88–132 Vac or 90–150 Vdc)

Part Number	Actuator Current (mA)	Forward/Reverse Acting	Actuator Tandem/Single	Decel Ramp
9905-030	0–200	Forward	Single	No
9905-031	0–200	Reverse	Single	No
9905-032	0–400	Forward	Single	No
9905-033	0–400	Reverse	Single	No
9905-034	0–200	Forward	Tandem	No
9905-035	0–200	Reverse	Tandem	No
9905-036	0–20	Forward	Single	No
9905-037	0–20	Reverse	Single	No
9905-038	0–200	Forward	Single	Yes
9905-039	0–200	Reverse	Single	Yes

### IMPORTANT

The 20–40 Vdc input power must be supplied from a power supply/battery charger certified to IEC standard with SELV (Safety Extra Low Voltage) classified output. The installer should properly size wiring and fusing for the input power and PT/CT circuits.

### Speed Ranges

On these Woodward 2301A models, any one of the following speed ranges may be selected by a switch:

500 to 1500 Hz	1000 to 3000 Hz
2000 to 6000 Hz	4000 to 12 000 Hz

### Power Supply Voltage

These Woodward 2301A controls accept either a high-voltage or a low-voltage power source. The low voltage models operate on 20 to 40 Vdc, and the high voltage models operate on either 88 to 132 Vac or 90 to 150 Vdc. Both the low- and high-voltage models require a power capacity of 15 W minimum.

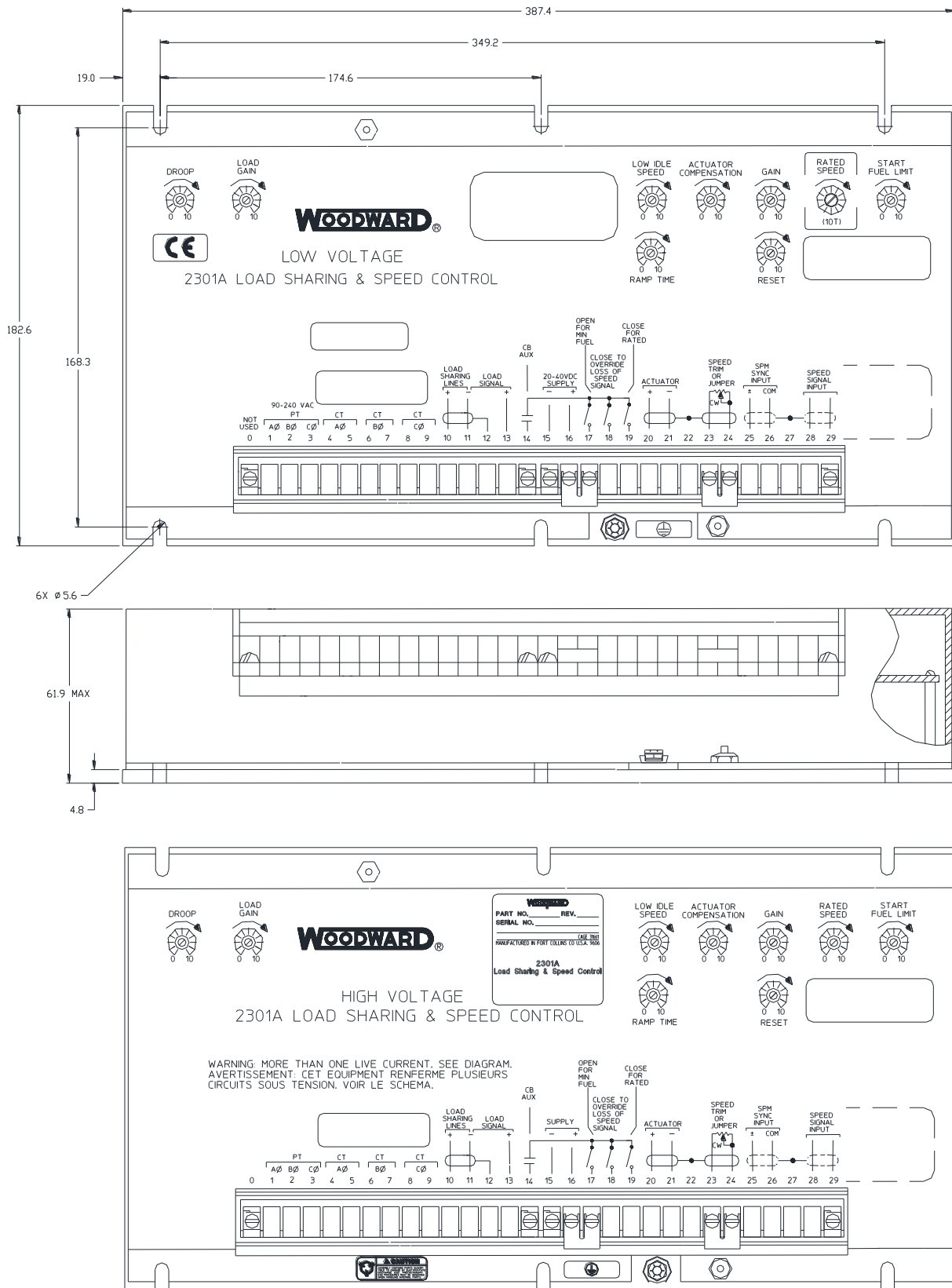

823-234A  
2013-7-24

Figure 1-1. 2301A Control Outline Drawing  
(low voltage version—top, high voltage version—bottom)

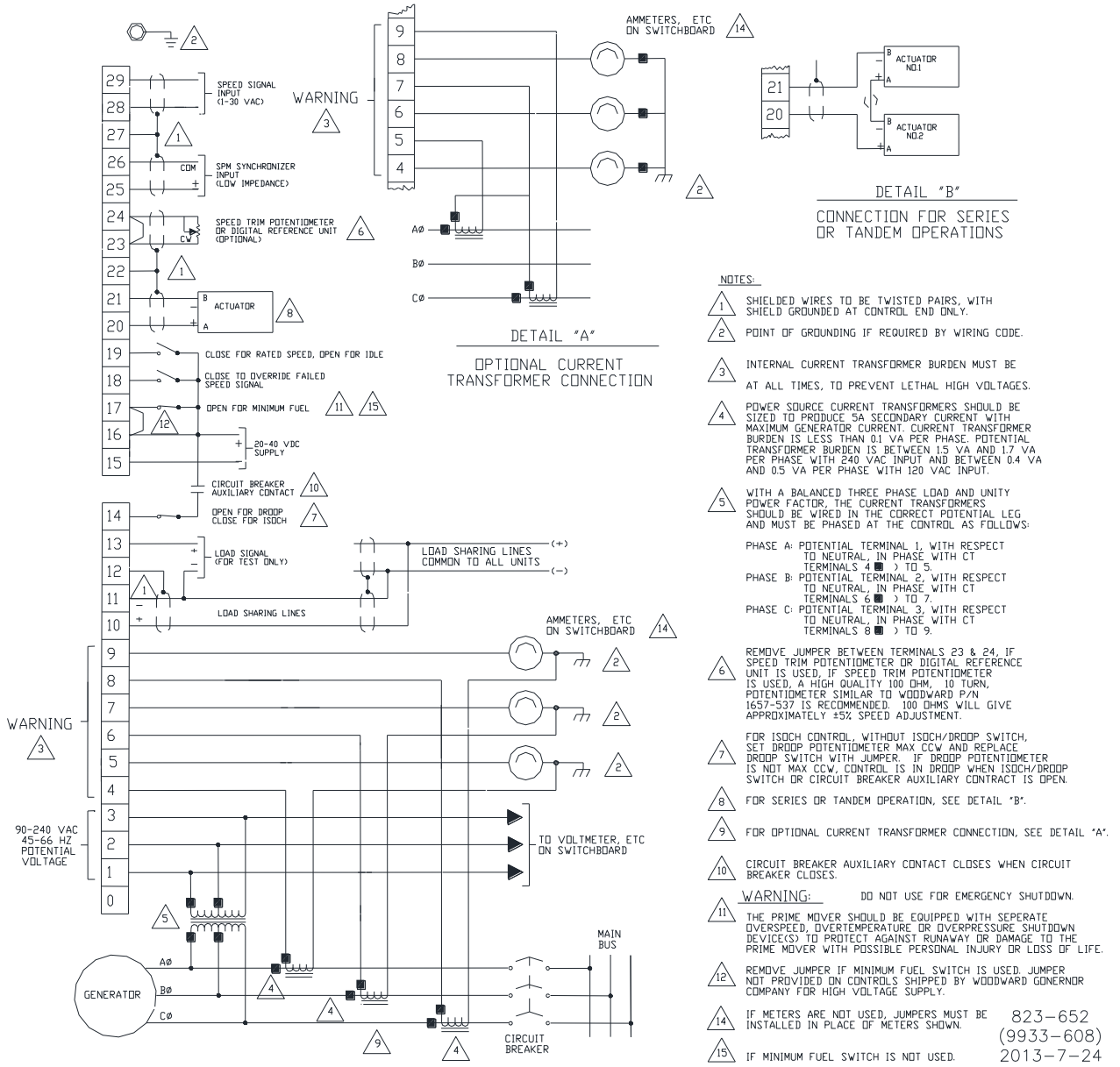

Figure 1-2a. Plant Wiring Diagram (low-voltage supply)

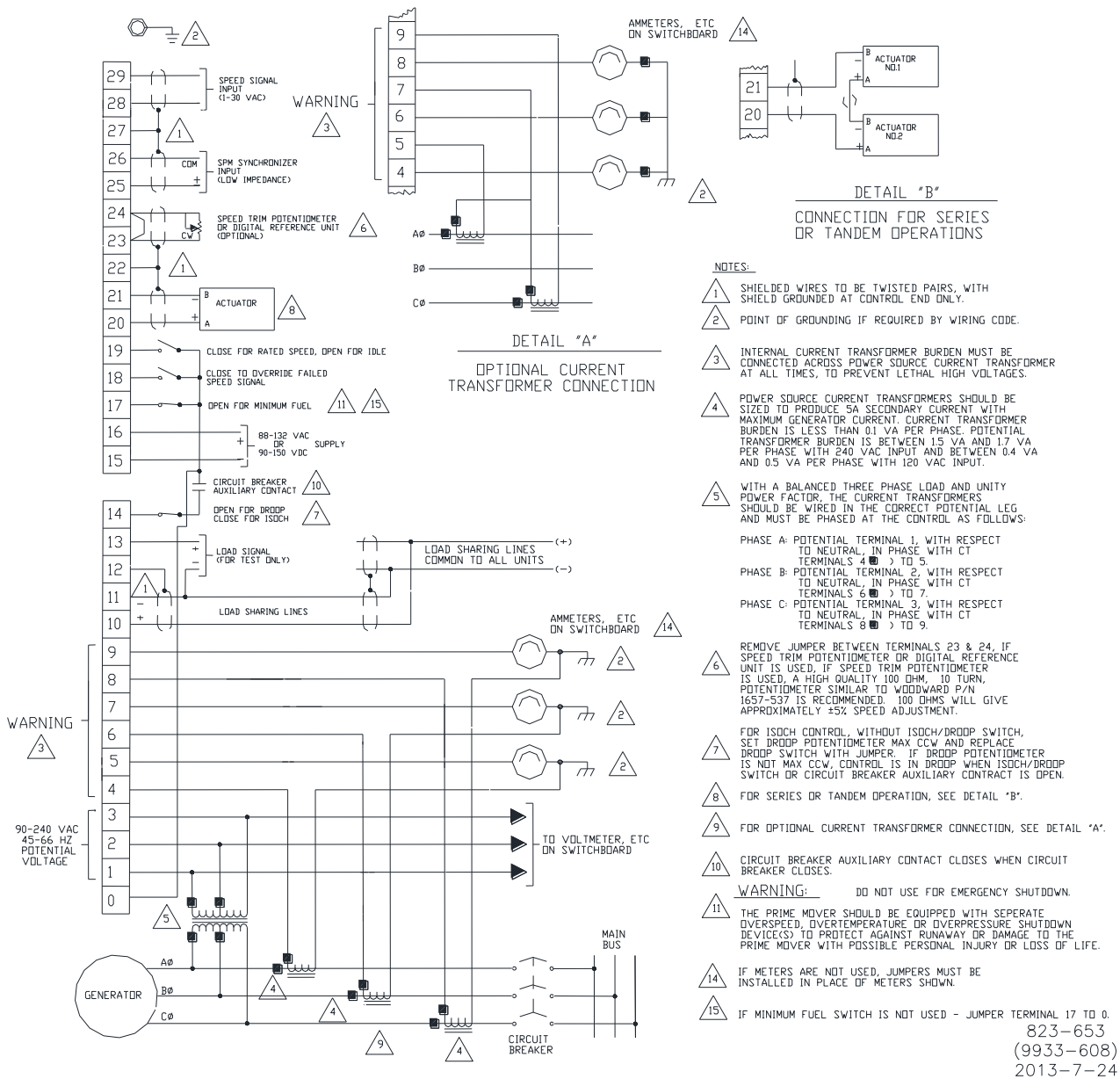

Figure 1-2b. Plant Wiring Diagram (high-voltage supply)

## Chapter 2. Installation

### Unpacking

Before handling the control, read the “Electrostatic Discharge Awareness” precautions on page iii. Be careful when unpacking the electronic control. Check the control for signs of damage such as bent or dented panels, scratches, and loose or broken parts. If any damage is found, immediately notify the shipper.

### Power Requirements

The 2301A control requires a voltage source of 18 to 40 Vdc, 90 to 150 Vdc, or 88 to 132 Vac for operating power (15 W). If a battery is used for operating power, an alternator or other battery charging device is necessary to maintain a stable supply voltage.

#### **NOTICE**

To prevent damage to the control, make sure that the alternator or other battery-charging device is turned off or disconnected before disconnecting the battery from the control.

### Location Considerations

*This product is intended for installation in a “closed electrical operating area” or in a closed industrial control cabinet.* Consider these requirements when selecting the mounting location:

- Adequate ventilation for cooling
- Space for servicing and repair
- Protection from direct exposure to water or to a condensation-prone environment
- Protection from high-voltage or high-current devices, or devices which produce electromagnetic interference
- Avoidance of vibration
- Selection of a location that will provide an operating temperature range of –40 to +70 °C (–40 to +158 °F)
- The control must NOT be mounted on the engine.

### Electrical Connections

External wiring connections and shielding requirements for a typical control installation are shown in the plant wiring diagram (Figure 1-2). These wiring connections and shielding requirements are explained in the balance of this chapter.

## Shielded Wiring

All shielded cable must be twisted conductor pairs. Do not attempt to tin (solder) the braided shield. All signal lines should be shielded to prevent picking up stray signals from adjacent equipment. Connect the shields to the control terminals as shown in Figure 2-1 and in the plant wiring diagram (Figure 1-2). Wire exposed beyond the shield should be as short as possible, not exceeding 50 mm (2 inches). The other end of the shields must be left open and insulated from any other conductor. Do not run shielded signal wires with other wires carrying large currents. See Woodward application note 50532, *EMI Control for Electronic Governing Systems*, for more information.

Where shielded cable is required, cut the cable to the desired length and prepare the cable as instructed below and shown in Figure 2-1.

1. Strip outer insulation from BOTH ENDS, exposing the braided or spiral wrapped shield. DO NOT CUT THE SHIELD.
2. Using a sharp, pointed tool, carefully spread the strands of the shield.
3. Pull inner conductor(s) out of the shield. If shield is the braided type, twist to prevent fraying.
4. Remove 6 mm (1/4 inch) of insulation from the inner conductor(s).
5. Connect wiring and shield as shown.

In installations with severe electromagnetic interference (EMI), shielded wire run in conduit, double shielded wire, or other precautions may be required. Contact Woodward for more information.

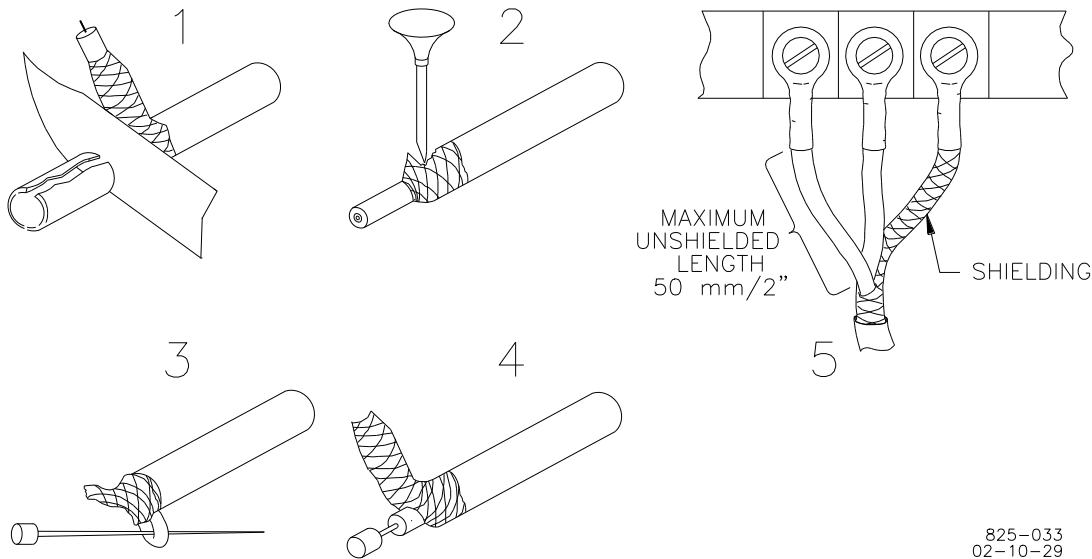

Figure 2-1. Preparation and Installation of Shielded Cables

## Setting Speed Range

The speed range to be selected is determined by the maximum desired prime mover speed. Calculate the frequency of the speed sensor signal at the maximum prime mover speed by multiplying the gear speed in revolutions per minute times the number of teeth on the speed sensing gear and dividing by 60. Select the lowest speed range which contains this maximum speed sensor frequency.

Figure 2-2 shows the four sections of Switch S1 and their corresponding speed ranges. Set the proper section of Switch S1 to the ON position and the other three positions of Switch S1 to the OFF position.



## WARNING

The speed range is factory set for 2000 to 6000 Hz. Refer to the inside cover to change speed range and prevent possible overspeed. Using the wrong speed range could cause an overspeed with resulting damage to equipment and/or personal injury or death.

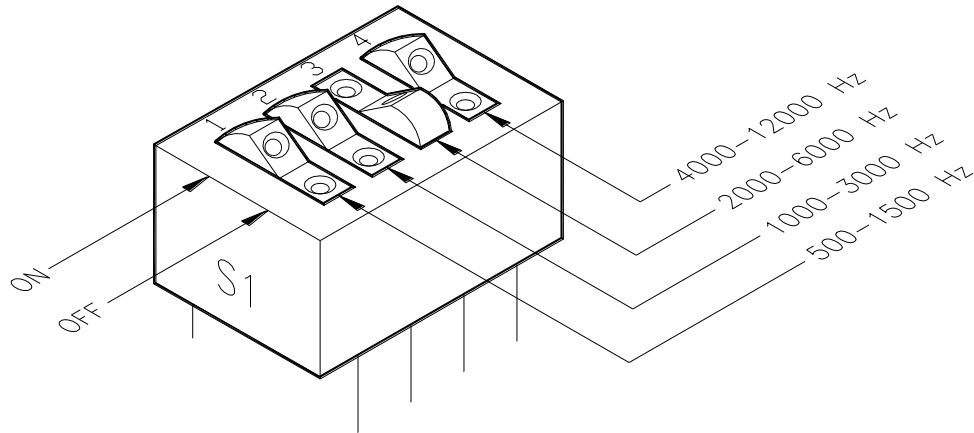

SWITCH S1

Figure 2-2. Switch S1

82300-A-176  
90-07-30 MCL

Variations in switch type may differ from that shown in Figure 2-2. The ON position is such that the switch is in its FULLY-DEPRESSED position on the side of the switch with the SWITCH NUMBER indicators.

## Potential Transformer Connections

Connect the potential transformer secondary leads to the following terminals:

- Phase A to terminal 1
- Phase B to terminal 2
- Phase C to terminal 3

The potential transformer secondary line-to-line voltage must be in the 90 to 240 Vrms range. Refer to the plant wiring diagram (Figure 1-2).

## Current Transformer Connections

The standard method of connecting the current transformers is shown in the plant wiring diagram (Figure 1-2). An alternate method is the open delta connection shown in the insert in the plant wiring diagram.

## Droop Contact (Isoch-Droop) and Load Sharing Lines

Because the load-sharing-line relay is contained in the control, no relay is required between the control and the load-sharing-line bus. Use shielded cable and connect the load-sharing lines directly to terminals 10 (+) and 11 (-). Connect the shield to terminal 12. When all controls in the system are of the 2301A type, the shields may be connected continuously between controls. When load sharing with different controls, do not connect the shields at the point where connections are made to the load-sharing-line bus.

The droop contact for selecting droop or isochronous operation is wired in series with the circuit-breaker auxiliary contact between terminal 14 and terminal 16 (terminal 0 on high-voltage controls). When both the droop contact and circuit-breaker auxiliary contact are closed, the control is in the isochronous load-sharing mode (Figure 2-3, A). In this mode, the internal load-sharing-line relay is energized, the droop signal is disabled (permitting isochronous load sharing), and the load-matching circuit is connected to the load-sharing lines.

The control is in the droop mode when EITHER the droop contact or the circuit-breaker auxiliary contact is open (Figure 2-3, B). If the droop contact is open, the control remains in the droop mode even when the circuit-breaker auxiliary contact is closed.

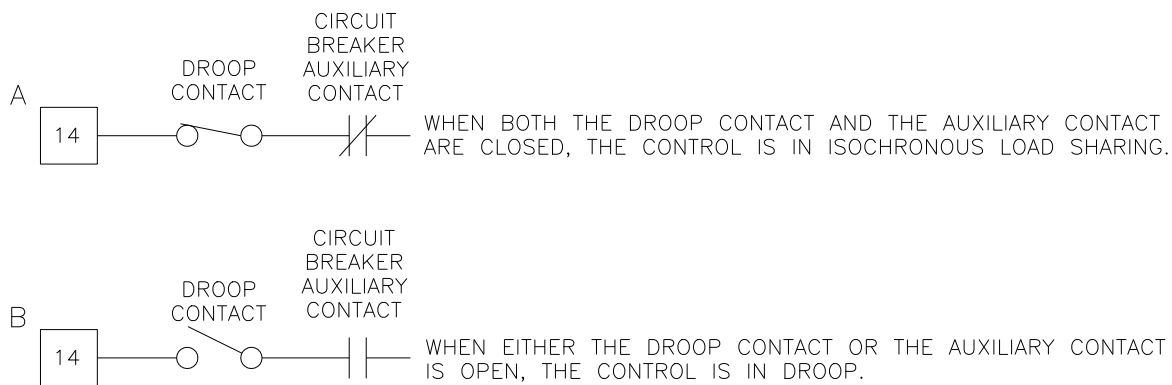

823-177  
98-11-16 skw

Figure 2-3. Droop Contact and Circuit Breaker Auxiliary Contact

### IMPORTANT

The control is in the droop mode whenever the circuit-breaker auxiliary contact is open. If a single prime mover is required to run isochronously with an isolated load, turn the DROOP potentiometer fully counterclockwise (*be careful not to overtorque the pot*).

Droop operation is required when the generator is paralleled with an infinite bus without a Generator Loading Control, Process Control, Automatic Power Transfer and Load Control, Import/Export Control, or other load controlling accessory, or when paralleled with incompatible governors. (All Woodward electric load-sharing systems are compatible.) When running a single unit on an infinite bus with a Generator Loading Control or Import/Export Control, terminal 14 must be connected to terminal 16 (terminal 0 on high-voltage controls) to connect the Load Matching Circuit to the load-sharing lines. The load-sharing lines must be wired to the Generator Loading Control or Import/Export Control. The circuit-breaker auxiliary contact will then be connected to the Generator Loading Control or Import/Export Control and not to the 2301A Load Sharing and Speed Control.

## Power Supply

Run the power leads directly from the power source to the control, connecting the negative lead to terminal 15, and the positive lead to terminal 16. If the power source is a battery, be sure the system includes an alternator or other battery-charging device.

### **NOTICE**

**DO NOT apply power to the control at this time. Applying power before a control is completely connected may damage the control.**

## Minimum Fuel Contact

The minimum-fuel contact is intended as an optional means for a normal shutdown of the prime mover. It is connected in series with terminal 16 (terminal 0 on high-voltage controls) and terminal 17 as shown in the plant wiring diagram (Figure 1-2). Do NOT remove this jumper from terminal 17 unless a minimum fuel contact is installed; the control will not operate without 18 to 40 Vdc applied to terminal 17.

When the contact is closed, the voltage applied to terminal 17 allows the control to move the actuator to any position required for operating conditions.

### **WARNING**

**Do NOT use the minimum-fuel contact as part of any emergency stop sequence.**

## Failed Speed Signal Override

A contact to override the failed-speed-signal circuit can be installed in series with terminal 18 and the dc power to the control. When the contact is open, the control operates normally, turning the control output off in the event of a loss of speed signal. Closing the contact overrides the failed-speed-signal circuit as may be required for start-up.

Prior to start-up of the prime mover, the speed signal is nonexistent. On prime movers with cranking motors, the cranking speed is usually sufficient to provide a speed signal, so an override contact on terminal 18 is not needed for starting. On some steam turbine systems, the Close to Override Failed Speed Signal contact must be closed in order to allow the actuator to open and provide steam for starting.

If a failed-speed-signal-override contact is used, it should be of the momentary type to ensure that the failed-speed-sensor shutdown circuit is enabled after start-up.

## Idle/Rated Ramp Contact

Connect a single-pole, single-throw contact from terminal 16 (terminal 0 on high-voltage controls) to terminal 19, the Close For Rated (open for idle, close for rated) terminal. Oil pressure is often used to close this contact. When closed, 20 to 40 Vdc is applied to terminal 19, and the prime mover can be operated at a speed higher than idle. When the contact is open, the voltage is removed from terminal 19, and the prime mover's speed immediately decelerates to idle.

## Actuator Output

The actuator wires connect to terminals 20 (+) and 21 (–). Use shielded wires with the shield connected to terminal 22. Do not connect the shield to the actuator or any other point. The shield must have continuity the entire distance to the actuator, and must be insulated from all other conducting surfaces. Refer to the manuals listed in Chapter 1, References, table for additional information on actuator installation.

## External Speed Trim

A jumper must be connected to terminals 23 and 24 unless an optional remote Speed Trim potentiometer is used. If a Speed Trim potentiometer is used, connect it as shown in the plant wiring diagram (Figure 1-2), using shielded wire. Connect the shield to terminal 22. Make sure the shield has continuity the entire distance to the potentiometer, and that the shield is insulated from all other conducting surfaces. A 100  $\Omega$  potentiometer will provide  $\pm 5\%$  speed adjustment. If less adjustment is desired, potentiometers of smaller values may be used. Potentiometers of the multi-turn type are recommended.

## Speed and Phase Matching (SPM) Synchronizer

Connect the SPM Synchronizer (optional equipment) wires to terminals 25 (+) and 26 (–). Use shielded wire, and connect the shield to terminal 27. Make sure the shield has continuity the entire distance to the SPM Synchronizer, but do not connect the shield to the synchronizer. The shield must be insulated from all other conducting surfaces.

## Speed Sensor

Connect a speed-sensing device, such as a magnetic pickup, to terminals 28 and 29 using shielded wire. Connect the shield to terminal 27, making sure the shield has continuity the entire distance to the speed sensor, and that the shield is insulated from all other conducting surfaces.

## Installation Check-out Procedure

With the installation completed as described in this chapter, do the following check-out procedure before beginning the start-up adjustments in Chapter 3.

### 1. Visual Inspection

- A. Check the linkage between the actuator and the prime mover for looseness or binding. Refer to the appropriate actuator manual and to Woodward manual 25070, *Electronic Governor Installation Guide*, for additional information on linkage.



**WARNING** The actuator lever should be near but not at the minimum position when the fuel or steam rack is at the minimum position. If the actuator lever gets to its minimum position before completely shutting off fuel or steam, the control may not be able to shut the turbine down, causing damage to equipment or injury or death.

- B. Check for correct wiring per the plant wiring diagram (Figure 1-2).
- C. Check for broken terminals and loose terminal screws.
- D. Check the speed sensor for visible damage. If the sensor is a magnetic pickup, check the clearance between the gear and the sensor, and adjust if necessary. Clearance should be between 0.25 and 1.00 mm (0.010 and 0.040 inch) at the closest point. Make sure the gear has less than 0.50 mm (0.020 inch) diametric runout. See Woodward manual 82510, *Magnetic Pickups & Proximity Switches for Electronic Governors*.

### 2. Check for Grounds

Make sure power is off. Check for grounds by measuring the resistance from terminal 11 to chassis, and from terminal 15 to 11. The resistance should measure  $>0.8 \text{ M}\Omega$ . If a resistance  $\leq 0.8 \text{ M}\Omega$  is obtained, remove the connections from each terminal one at a time until the resistance is  $>0.8 \text{ M}\Omega$ . Check the line that was removed last to locate the fault.

## Chapter 3. Operation and Adjustment

### Initial Pre-Start Settings

#### ! WARNING

Read this entire procedure before starting the prime mover.

#### NOTICE

The Rated Speed potentiometer is the only multi-turn pot in this control. All other pots are single-turn. Take care not to turn these pots beyond their stops.

1. RATED SPEED
  - A. Set the RATED SPEED potentiometer to minimum (fully counterclockwise).
  - B. Set the external Speed Trim, if used, to mid-position.
2. RESET—Set at mid-position.
3. GAIN—Set at mid-position.
4. RAMP TIME—Set at maximum (fully clockwise—**be careful not to overtorque the pot**).
5. LOW IDLE SPEED—Set at maximum (fully clockwise—**be careful not to overtorque the pot**).
6. LOAD GAIN—Set at mid-position.
7. DROOP—Set at minimum (fully counterclockwise—**be careful not to overtorque the pot**).
8. ACTUATOR COMPENSATION.
  - A. Set the ACTUATOR COMPENSATION potentiometer at 2 on the 0 to 10 potentiometer scale for diesel, gas turbine, or fuel-injected gasoline prime movers.
  - B. Set the ACTUATOR COMPENSATION potentiometer at 6 on the 0 to 10 potentiometer scale for carbureted-gas or gasoline prime movers, and steam turbines.
9. START FUEL LIMIT—Set at maximum (fully clockwise—**be careful not to overtorque the pot**).
10. Be sure that the actuator is connected to terminals 20 and 21.

### Start-Up Adjustments

1. Complete the installation checkout procedure in Chapter 2, and the initial prestart settings above.

#### NOTICE

Be sure the speed range switch is set on the right speed range for your application as described in Chapter 2.

2. Close the Close For Rated contact. Set the control for isochronous operation by closing the droop contact.

**IMPORTANT**

**This is for initial prime mover start-up only. For normal start-up, the Close For Rated contact (open for idle/close for rated) should be open if the prime mover is to start at idle.**

3. Apply input power to the control.
4. Preset rated speed.

If a signal generator is not used, set the RATED SPEED potentiometer at minimum (fully counterclockwise).

When using a signal generator to set rated speed, set the signal generator for the frequency of the speed sensor at rated speed, and connect it to terminals 28 and 29. (The rated speed frequency in Hz equals the rated prime mover speed in rpm times the number of teeth on the speed-sensing gear divided by 60.) Put the Close For Rated contact in the rated (closed) position. Set the speed trim potentiometer, if used, to mid-position. Connect a dc analog voltmeter to terminals 20 (+) and 21 (–) to read actuator voltage.

If the actuator voltage is at minimum (minimum will be approximately 0 volts), slowly turn the RATED SPEED potentiometer clockwise (counterclockwise for reverse-acting controls) until the voltage just begins to move to maximum.

If the actuator voltage is at maximum, slowly turn the RATED SPEED potentiometer counterclockwise (clockwise for reverse-acting controls) until the voltage just begins to move to minimum.

Continue to very slowly adjust the RATED SPEED potentiometer in the appropriate direction, trying to stop the actuator voltage between the minimum and maximum voltages. Because it is not possible to stop the motion, cease adjusting when the voltage changes slowly. The RATED SPEED potentiometer is now set very close to desired speed. A slight adjustment when the engine is running will achieve the exact speed.

5. Check the speed sensor.

Minimum voltage required from the speed sensor to operate the electronic control is 1.0 Vrms, measured at cranking speed or the lowest controlling speed. For this test, measure the voltage while cranking, with the speed sensor connected to the control. Before cranking, be sure to prevent the prime mover from starting. At 5% of the lower value of the control's speed range, the failed speed sensing circuit is cleared. For example 100 Hz is required on the 2000 to 6000 Hz speed range ( $2000 \text{ Hz} \times 0.05 = 100 \text{ Hz}$ ).

**WARNING**

**Be prepared to make an emergency shutdown when starting the engine, turbine, or other type of prime mover, to protect against runaway or overspeed with possible personal injury, loss of life, or property damage.**

6. Start the prime mover.

## Adjust For Stable Operation

If prime-mover operation is stable, go to the “Speed Setting Adjustment” procedure.

If the prime mover is hunting at a rapid rate, slowly decrease the GAIN (turn the potentiometer counterclockwise) until performance is stable. Adjusting the GAIN may cause a momentary speed change which can be minimized by turning the GAIN potentiometer slowly.

If the prime mover is hunting at a slow rate, increase the RESET (turn the potentiometer clockwise) until the prime mover stabilizes. If increasing the RESET potentiometer does not stabilize the prime mover, it also may be necessary to either:

- Slowly decrease the GAIN (turn the potentiometer counterclockwise) or
- Slowly decrease the GAIN and increase the ACTUATOR COMPENSATION.

## Speed Setting Adjustment

With the prime mover operating stably, and the external speed trim potentiometer (if used) set at mid-position, adjust the RATED SPEED potentiometer to bring the prime mover to the desired operating speed.

## Dynamic Adjustment

The object of the GAIN and RESET potentiometer adjustment is to obtain the optimum, or desired, stable prime-mover-speed response.

Connect a dc analog voltmeter to terminals 20 (+) and 21 (–) to monitor the actuator voltage.

### **IMPORTANT**

**Adjusting the GAIN may cause momentary changes in speed which can be minimized by turning the GAIN potentiometer slowly.**

Increasing the setting of the GAIN potentiometer provides faster transient response (decreases the magnitude of the speed change from a sudden change in load). To achieve optimum response, slowly increase the GAIN (turn the potentiometer clockwise) until the voltage on the voltmeter becomes slightly unstable, then slowly turn the GAIN back counterclockwise as necessary to stabilize the meter reading. Step load the generator, or bump the actuator terminal shaft, to make sure that the prime mover returns to the proper speed with little overshoot or undershoot of the speed setting. To reduce overshoot, increase the RESET (turn the potentiometer clockwise).

When the RESET potentiometer is in the lower part of its adjustment (0 to 3 on the potentiometer scale), increasing the RESET clockwise may require decreasing the GAIN (turning the GAIN potentiometer counterclockwise) to maintain stable operation.

If the prime mover is slow in returning to the proper speed, decrease the RESET by turning the potentiometer counterclockwise.

Figure 3-1 illustrates prime mover starts with the RAMP TIME potentiometer fully counterclockwise (no ramp—**be careful not to overtorque the pot**), step loadings at four different RESET potentiometer settings, and stable, steady-state running conditions. These are typical performance curves on a naturally aspirated (non-turbocharged) diesel engine.

**IMPORTANT**

Optimum performance is not necessarily obtained with the GAIN potentiometer at the maximum stable clockwise position. In some cases, the gain must be reduced slightly to ensure stability under widely varying conditions.

## Actuator Compensation Adjustment

If the ACTUATOR COMPENSATION is set as described under Initial Prestart Settings, no further adjustment is normally required. If a slow periodic instability remains, slightly increase the ACTUATOR COMPENSATION (turn the potentiometer clockwise), and repeat the GAIN and RESET adjustments. Continue to increase the ACTUATOR COMPENSATION and readjust the GAIN and RESET until stability is achieved.

If a fast instability or extremely active actuator is evident, slightly decrease the ACTUATOR COMPENSATION (turn the potentiometer counterclockwise). If necessary, the ACTUATOR COMPENSATION may be set fully counterclockwise (**be careful not to overtorque the pot**). This may be required when engine torsionals cause excessive fuel-linkage movement.

## Low Idle Speed Adjustment

1. The prime mover should be approximately at rated speed with the LOW IDLE SPEED potentiometer set at maximum (fully clockwise—**be careful not to overtorque the pot**). Open the external CLOSE FOR RATED contact.
2. Decrease the LOW IDLE SPEED (turn the potentiometer counterclockwise) until the recommended idle speed is reached.

**IMPORTANT**

Make certain that the prime-mover speed is controlled by the LOW IDLE SPEED potentiometer in a range above the minimum-fuel position (mechanical stop) of the actuator or prime-mover fuel rack.

## Ramp Time Adjustment

Adjust the RAMP TIME potentiometer to achieve satisfactory prime mover acceleration to rated speed with minimum overshoot. First, start at the fully clockwise (maximum ramp time—**be careful not to overtorque the pot**) position and work back in the counterclockwise direction until the unit ramps as rapidly as desired.

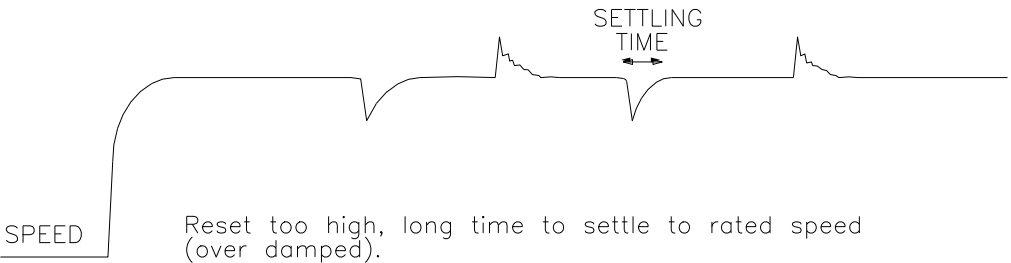
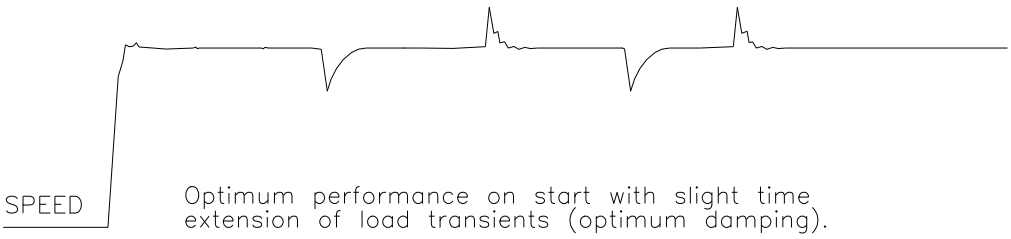
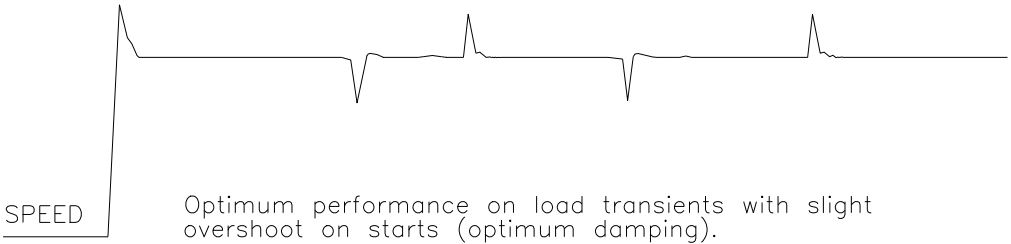
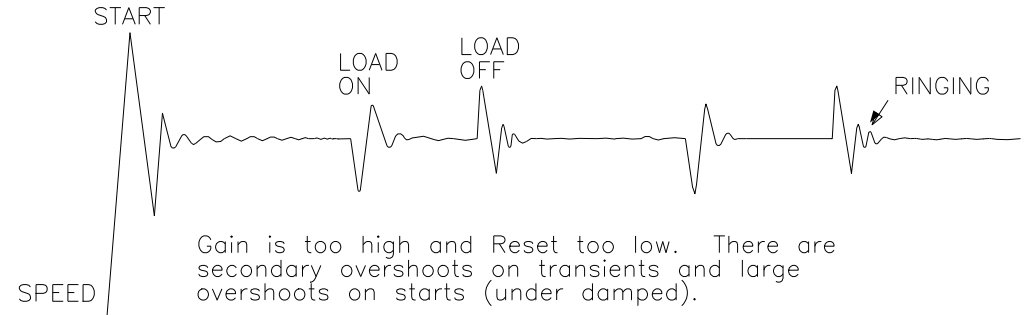

825-303  
97-10-28 skw

Figure 3-1. Diesel Engine Performance Curves

## Start Fuel Limit Adjustment

### IMPORTANT

Start-fuel limit is not recommended for use with reverse-acting controls. With loss of speed signal, the reverse-acting control will position the actuator at the start-fuel level if the failed-speed-signal override is activated. Reverse-acting systems normally require the control to demand full fuel on loss of speed signal to allow the mechanical backup governor to control the system. The Start Fuel Limit can be deactivated by turning the potentiometer fully clockwise (*be careful not to overtorque the pot*).

With the prime mover operating at rated speed and no load, record the voltage across actuator terminals 20 (+) and 21 (-). Shut down the prime mover and activate the Failed Speed Signal Override by closing the override contact. The voltage to the actuator should now be adjustable by the START FUEL LIMIT potentiometer. Set the actuator voltage approximately 10% higher than the voltage obtained at rated speed for forward-acting controls and 10% lower than rated speed voltage for reverse-acting controls. Remove the Failed Speed Signal Override contact if not required to start the prime mover.

Start the prime mover and observe the start time, overshoot of speed setting, and smoke emissions obtained. The START FUEL LIMIT may be adjusted as required to optimize the prime-mover starting characteristics. The fuel-limiting function is turned off automatically when the speed control takes over.

### IMPORTANT

For prime movers not requiring start-fuel limiting, the START FUEL LIMIT function can be deactivated by turning the potentiometer fully clockwise (*be careful not to overtorque the pot*).

## Speed Sensor Check

If the sensor is a magnetic pickup, measure the voltage across terminals 28 and 29 to be sure there is a minimum of 1.0 V at cranking speed, and a maximum of 30 Vrms at rated speed. If the voltage exceeds 30 V, increase the gap of the speed sensor, and be sure that there is still a minimum of 1.0 V at cranking speed.

## Current Transformer (CT) Phasing Check

### IMPORTANT

This control contains internal current transformers. Due to their low impedance, shorting their inputs is not effective. The current input must be removed from the control and shorted externally.

### WARNING

**HIGH VOLTAGE**—Never disconnect any wire attached to load sensor terminals 4 through 9 when the prime mover is running unless temporary 1  $\Omega$ , 5 W resistors are installed as shown in Figure 3-2, and all load is removed. The current transformers can develop dangerously high voltages when open circuited while the prime mover is running.

1. Connect a dc voltmeter to control terminals 11 (–) and 13 (+) to measure the load signal.
2. Start the prime mover. With the generator operating in the isochronous mode and not paralleled, load the generator to as near to full load as possible. Measure the load-signal voltage.
3. Unload and shut down the prime mover. Disconnect the wire from terminal 5, and connect both wires from phase A CT to terminal 4.
4. Start the prime mover, apply full load (or the same load as obtained in step 2) and again measure the load signal at terminals 11 and 13. If the load signal voltage is not 1/3 lower than the reading obtained in step 2, the phasing is incorrect. Unload and shut down the prime mover. Reconnect phase A CT wire from terminal 4 to terminal 5, maintaining the original polarity.

If the phasing is incorrect, proceed to the Phase Correction Procedure.

If the phasing appears correct, skip the Phase Correction Procedure and go to the Load Gain Adjustment procedure.

**IMPORTANT**

If after completing the LOAD GAIN and DROOP adjustments, the control loading is extremely sensitive to changes in the power factor when operating in parallel, complete the Phase Correction Procedure.

## Phase Correction Procedure

**IMPORTANT**

This procedure requires a minimum power factor of 0.9. If a 0.9 power factor cannot be obtained, tracing through the wiring is the only means of correcting the current-transformer phasing.

The highest positive voltage will be obtained when the CTs are correctly matched to the load-sensor terminals in both phase and polarity. The following procedure will assure the correct connection of the current transformers. It is required only if the phasing check indicates incorrect phasing, or loading stability is extremely sensitive to the power factor.

Trial connections of the first CT to all three load-sensor inputs, polarized both ways, are made (a total of six connections). The load-signal voltage is recorded for each connection and the first CT is then connected to the terminals that produce the highest positive voltage, and with the polarity that produces the highest positive voltage.

The second CT is tried on each of the remaining two CT input terminals, in each polarity, and the voltage recorded. The second CT is then connected to the terminals that produce (and with the polarity that produces) the highest positive voltage.

The last CT is then tried on the remaining input terminals, polarized both ways, and the voltage recorded. Connecting the last CT in the polarity that produces the highest voltage completes the procedure.

The Phase Correction Procedure requires that the prime mover be shut down many times to disconnect the current transformers. For convenience, a temporary method of connecting the current transformers shown in Figure 3-2 is recommended. Connecting a 1  $\Omega$ , 5 W burden resistor across each current transformer allows the current transformers to be disconnected from the terminal strip with the prime mover running, after removing all load.

!
**WARNING**

**HIGH VOLTAGE**—The current transformers can develop dangerously high voltages. Do not disconnect a current transformer while the prime mover is running unless temporary 1  $\Omega$ , 5 W resistors are installed as shown in Figure 3-2, and all load is removed.

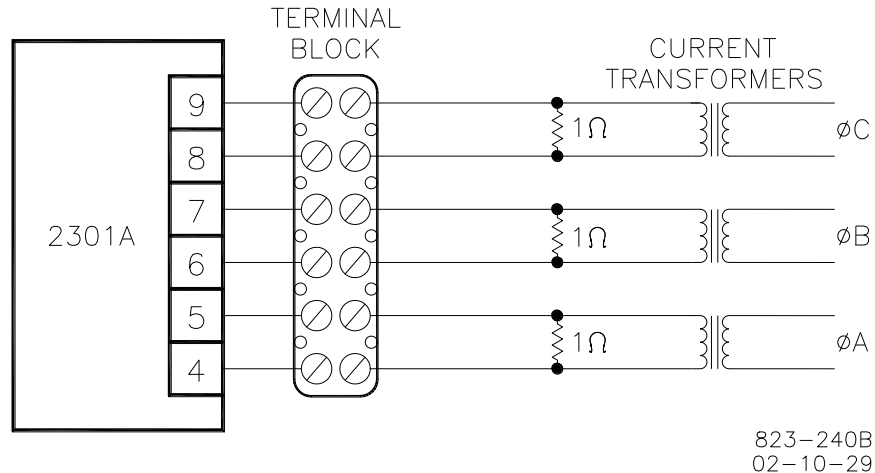

Figure 3-2. Temporary Wiring for Transformer Phase Correction

If the temporary burden resistors described above and shown in Figure 3-2 are not used, the prime mover **MUST** be shut down in addition to removing the load in the following procedure.

Measure the load-signal voltage in this procedure by connecting a voltmeter across the Load Signal terminals 11 (–) and 13 (+).

1. Shut down the prime mover.
2. Label each CT wire with the phase and polarity that you think it should be. Even though this identification may prove to be incorrect, this step is necessary so that the individual wires may be identified during the description of the procedure.
3. Disconnect the phase B CT wires from terminals 6 and 7. Connect these two wires together using a small screw and nut, and tape the connection.
4. Disconnect the phase C CT wires from terminals 8 and 9. Connect and tape these two wires together as in step 3.
5. Connect the two wires from the phase A CT to the phase A input terminals 4 and 5.
6. Start the prime mover, apply full load, and measure the load signal voltage. Start a list and record this voltage.

7. Unload the system and reverse the phase A CT wires on terminals 4 and 5. \*
8. Apply full load, measure the load signal, and record this voltage.
9. Unload the system, remove the phase A CT wires from terminals 4 and 5, and connect them to phase B input terminals 6 and 7. \*
10. Apply full load, measure the load signal, and record this voltage.
11. Unload the system and reverse the phase A CT wires on terminals 6 and 7. \*
12. Apply full load, measure the load signal, and record this voltage.
13. Unload the system, remove the phase A CT wires from terminals 6 and 7, and connect them to phase C input terminals 8 and 9. \*
14. Apply full load, measure the load signal, and record this voltage.
15. Unload the system and reverse the phase A CT wires on terminals 8 and 9. \*
16. Apply full load, measure the load signal, and record this voltage.
17. Unload the system and compare the six voltage readings. \*
18. Remove the phase A CT wires from terminal 8 and 9 and connect the phase A wires to the pair of terminals that produced the highest positive load-signal voltage and in the polarity that produced the highest positive load-signal voltage.
19. Untape and disconnect the phase B CT wires. Connect the phase B CT wires to one pair of the two remaining pair of CT input terminals on the load sensor.
20. Apply full load and measure the load signal. Start a new list and record this voltage.
21. Unload the system, and reverse the phase B CT wires on the same terminals. \*
22. Apply full load, measure the load signal, and record this voltage.
23. Unload the system, remove the phase B CT wires, and connect them to the other pair of terminals. \*
24. Apply full load, measure the load signal, and record this voltage.
25. Unload the system and reverse the phase B CT wires on the same terminals. \*
26. Apply full load and measure the load signal. Record this voltage, and compare the four voltages on the list.
27. Unload the system. Remove the phase B CT wires and connect them to the pair of CT input terminals that produced the highest positive load signal voltage and with the polarity that produced the highest positive load signal voltage. \*

28. Untape and disconnect the phase C CT wires. Connect these two wires to the remaining pair of CT input terminals.
29. Apply full load, measure the load signal, and record this voltage.
30. Unload the system and reverse the phase C CT wires on the same terminals. \*
31. Apply full load, measure the load signal, and record this voltage.
32. Unload and shut down the system. Compare the two voltages. \*
33. Connect the phase C CT wires to the same pair of CT input terminals, but in the polarity that produced the highest positive load-signal voltage.
34. Re-label each wire with the phase designation of the terminal that it is now connected to.
35. Remove the burden resistors and terminal block.

**\*—Be sure to shut down the prime mover if the temporary burden resistors are not used.**

## Load Gain Adjustment

For this procedure, the generator must be running isochronously and not paralleled. Connect a dc voltmeter across terminals 11 (–) and 13 (+) to measure the load-signal voltage.

Start the prime mover and apply full load. Measure the load signal voltage and adjust the LOAD GAIN potentiometer for 6.0 V. \* If full load is not obtainable, decrease the LOAD GAIN proportionally to the load. For example, at 50% load adjust the LOAD GAIN to 3 V.

When paralleled in the isochronous mode or on an isolated bus, generator speeds must be the same. If they are not equal, load sharing will not remain proportional as the load varies. Any difference in loads between the units can be corrected by adjusting the Load Gain Potentiometer. Increasing the LOAD GAIN (turning the potentiometer clockwise) will cause that generator to carry less load. If stability problems occur when paralleled at a particular load-signal voltage, reduce the voltage by reducing the LOAD GAIN (turn the potentiometer counterclockwise), and reduce the load-signal voltage setting of all other generators in the system to the same voltage. When the load-signal voltages of all generators in a system are reduced, the load-sharing gain will be reduced, and this may result in some loss of load-sharing sensitivity.

- \* If 6 volts at full load (or a lower voltage proportional to a load less than 100%) cannot be obtained, and the phasing has been checked and is correct, the current transformers are probably the wrong size. The current-transformer output must be from 3 to 7 A (5 A nominal) at full load.

It may be necessary to reduce the load-signal voltage of each unit in the system to as low as 3 V in cases of extremely poor system dynamics. If your system requires a load-signal voltage as low as 3 V, consult Woodward for suggestions for possible remedies.

## Droop Adjustment

Adjustment of the DROOP potentiometer is necessary when the generator set is to be operated in the droop mode. Droop in a load sensor is usually expressed as a percentage and calculated by the following formula.

$$\% \text{ Droop} = \frac{\text{No Load Speed} - \text{Full Load Speed}}{\text{No Load Speed}} \times 100$$

The method of setting droop depends on whether the load of the generator set is an isolated load or an infinite bus.

### Setting Droop for an Isolated Load

1. Open the droop contact connected to terminal 14.
2. Start the prime mover and adjust the RATED SPEED potentiometer for rated speed with no load.
3. Apply full load. \*
4. Adjust the DROOP potentiometer to give the desired speed.

Example: Operating at 60 Hz, 57 Hz at full load indicates 5% droop.

\*—If only 50% loading is possible, 58.5 Hz would indicate 5% droop (see Figure 3-3).

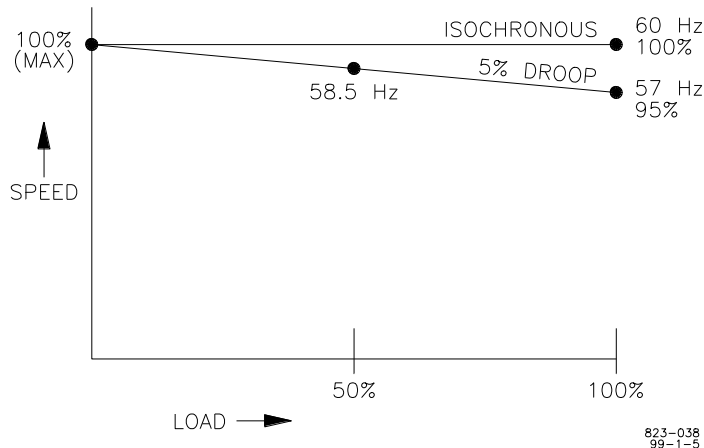

Figure 3-3. Droop Adjustment

### Setting Droop when Against Utility

Use the following procedure to set the Droop and Load Gain potentiometers with the utility as the only load.

1. Calculate the fully loaded speed (or frequency) of the generator when running at 100% load.  
 No Load frequency = rated frequency x (1 + droop %)  
 Example: Rated frequency = 60.0 Hz  
 Desired droop = 3% (0.03)  
 No Load Frequency = 60 x (1 + 0.03) = 61.8

2. Run the generator at the speed calculated in step 1, with no load. Record the setting of your speed-setting device:
  - Potentiometer—record setting with a pencil mark.
  - MOP or Other—measure and record the value of the speed-setting voltage (at the control).
3. Reduce system speed to rated (frequency).
4. Preset both the Load Gain and Droop potentiometers fully clockwise (**be careful not to overtorque the pot**).

### WARNING

If when you close the breaker, the load on the unit increases rapidly, open the breaker and shut the unit down. Check the phasing of the CTs and PTs. Permitting the unit to continue to pick up load or continuing to operate the system without correcting this condition may cause damage to equipment, and injury or death to personnel.

5. Synchronize, close the generator breaker, and increase the load by increasing the speed setting to the setting recorded in step 2.

### NOTICE

The adjustments in steps 6 and 7 are non-linear. Make changes in small increments to prevent overload.

6. Increase the load on the unit by turning the Droop potentiometer counterclockwise until the Load Gain Voltage reads 6.0 Vdc \*.
7. Increase load by turning the Load Gain potentiometer counterclockwise until the load is at the desired 100% value.

### IMPORTANT

\*—Most systems use a Load Gain Voltage of 6.0 Vdc at full load. To perform this procedure at less than full load, use a Load Gain Voltage value that is proportional to the percent load used. For example, if the Load Gain Voltage at full load is 6.0 Vdc, you would adjust for a Load Gain Voltage of 3.0 Vdc at 50% load.

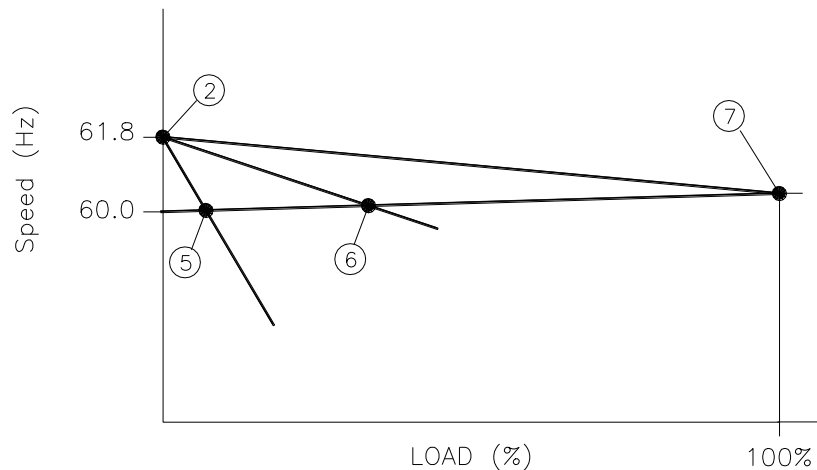

3% Droop at 60 Hz

823-221  
97-11-21 skw

Figure 3-4. 3% Droop at 60 Hz

# Chapter 4.

## Description of Operation

### Introduction

The speed and load sharing section of these 2301A models monitors and controls two functions.

- **Speed**—The speed control section keeps the prime mover at the correct speed.
- **Load Sharing**—During parallel operation of two or more generators, the load sharing section senses the load carried by its generator and causes the loads of all generators in the system to be shared proportionally.

### Speed Control

The Speed Control system as shown in Figure 4-1 consists of:

- a device (1) to sense the speed of the prime mover
- a Frequency to Voltage Converter (2)
- a Speed Reference (3) to which the prime mover speed can be compared
- A Speed Summer/Amplifier (4) with an output proportional to the amount of fuel or steam required to maintain the desired speed at any given load
- An Actuator (5) to position the fuel or steam mechanism of the prime mover

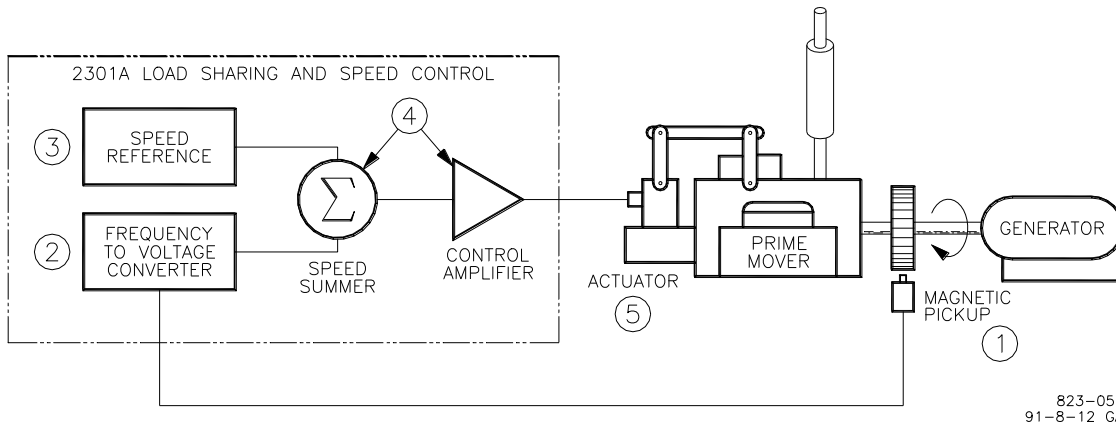

Figure 4-1. Speed Control System

A speed-sensing device, such as a magnetic pickup, senses the speed of the prime mover, and converts it to an ac signal with a frequency proportional to prime-mover speed.

The frequency-to-voltage converter receives the ac signal from the speed sensor and changes it to a proportional dc voltage.

A speed-reference circuit generates a dc “reference” voltage to which the speed-signal voltage is compared. See Woodward manual 82510, *Magnetic Pickups & Proximity Switches for Electronic Controls*, for more information on magnetic pickups.

The speed-signal voltage is compared to the reference voltage at the summing point. If the speed-signal voltage is lower or higher than the reference voltage, a signal is sent by the control amplifier calling for an increase or decrease in speed.

The actuator responds to the signal from the control amplifier by repositioning the fuel or steam rack, changing the speed of the prime mover until the speed-signal voltage and the reference voltage are equal.

A failed-speed-signal circuit monitors the speed-signal input. When no signal is detected, it calls for minimum fuel. The minimum-fuel signal is sufficient to cause the actuator to go to the minimum position if not restricted. However, due to linkage adjustment or other restrictions in the external system, minimum actuator position may not permit prime-mover shutdown.

For controls with actuator current of 20 to 160 mA, minimum fuel is defined as:

- Actuator current less than 10 mA for forward-acting controls.
- Actuator current greater than 180 mA reverse-acting controls.

For controls with actuator current of 40 to 320 mA, minimum fuel is defined as:

- Actuator current less than 20 mA for forward-acting controls.
- Actuator current greater than 360 mA for reverse-acting controls.

A contact to override the failed-speed-signal circuit can be connected in series with terminal 18 and terminal 16 (or terminal 0 on high voltage controls). Temporarily closing the contact overrides the failed-speed-signal circuit, which may be required for start-up.

Because of the variety of installations, plus system and component tolerances, the control must be tuned to each system for optimum performance. The potentiometers for setting and adjusting these circuits are located in the upper right corner of the control as shown in Figure 4-2. They include:

- the RATED SPEED potentiometer
- the START FUEL LIMIT potentiometer
- RESET, GAIN, and ACTUATOR COMPENSATION
- RAMP TIME and LOW IDLE SPEED potentiometers

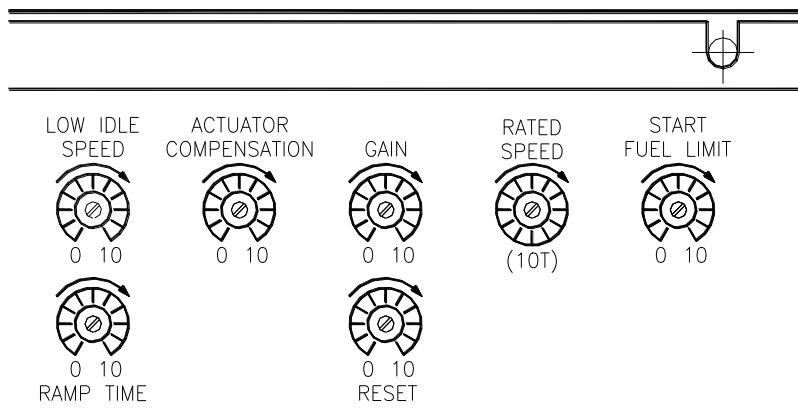

Figure 4-2. Speed Control Adjustments

The RATED SPEED potentiometer is adjusted so that at rated speed, the converter-speed voltage and the reference-speed voltage are equal.

The START FUEL LIMIT potentiometer provides a means of limiting the fuel-rack position when starting diesel engines. Adjustment of the potentiometer sets the maximum actuator position desired. This limit position is automatically enabled prior to start-up, and is turned off when speed control takes over.

RESET, GAIN and ACTUATOR COMPENSATION potentiometers adjust the control amplifier to accommodate various types of prime-mover systems. The RESET adjustment affects prime mover reaction time when recovering after a sudden load change. The magnitude of the speed change resulting from a sudden change in load is controlled by adjusting the GAIN. ACTUATOR COMPENSATION compensates for the time the actuator and prime mover system takes to react to signals from the control.

The time taken by the prime mover to accelerate from idle to rated speed, and the recommended idle speed, are set with the RAMP TIME and LOW IDLE SPEED potentiometers respectively.

## Terminals for External Devices

Terminal blocks for wiring the control to the system are at the lower front panel of the control. Additional terminals are included for connecting other external devices as shown in Figure 4-3.

## Paralleling

There are two basic methods used for paralleling: droop, where speed decreases with load, and isochronous, where speed remains constant. The paralleling system as shown in Figure 4-4 consists of:

- Load Matching circuit (1)
- a Load Amplifier circuit (2)

An auxiliary contact on the generator tie-breaker connected from terminal 16 (or terminal 0 on high voltage controls) to terminal 14 is used to select isochronous load-sharing operation. A contact in series with the auxiliary contact may be used to select either the droop or isochronous mode of operation.

If either the auxiliary contact or the droop contact is open, the control is in droop. When they are both closed, the control is in isochronous load sharing.

With only one unit on line, the generator picks up the available load and remains at isochronous speed. If additional units are on line, the Load Matching circuit corrects the fuel output to proportion load.

An amplifier in the load-sensing circuit computes the load carried by each phase of the generator. The current load on each phase is multiplied by the cosine of the phase difference between the current and the voltage, and the three phases are added to determine the total load.

The output of the load amplifier is adjusted by the LOAD GAIN potentiometer shown in Figure 4-5. By setting the load-gain voltage on each unit to the same level at full load, proportional load sharing is achieved. Regardless of differences in generator-set capacities in the system, each generator set is loaded to the same percentage of its capacity. A final adjustment of the individual LOAD GAIN potentiometers will compensate for minor differences in the generator sets.

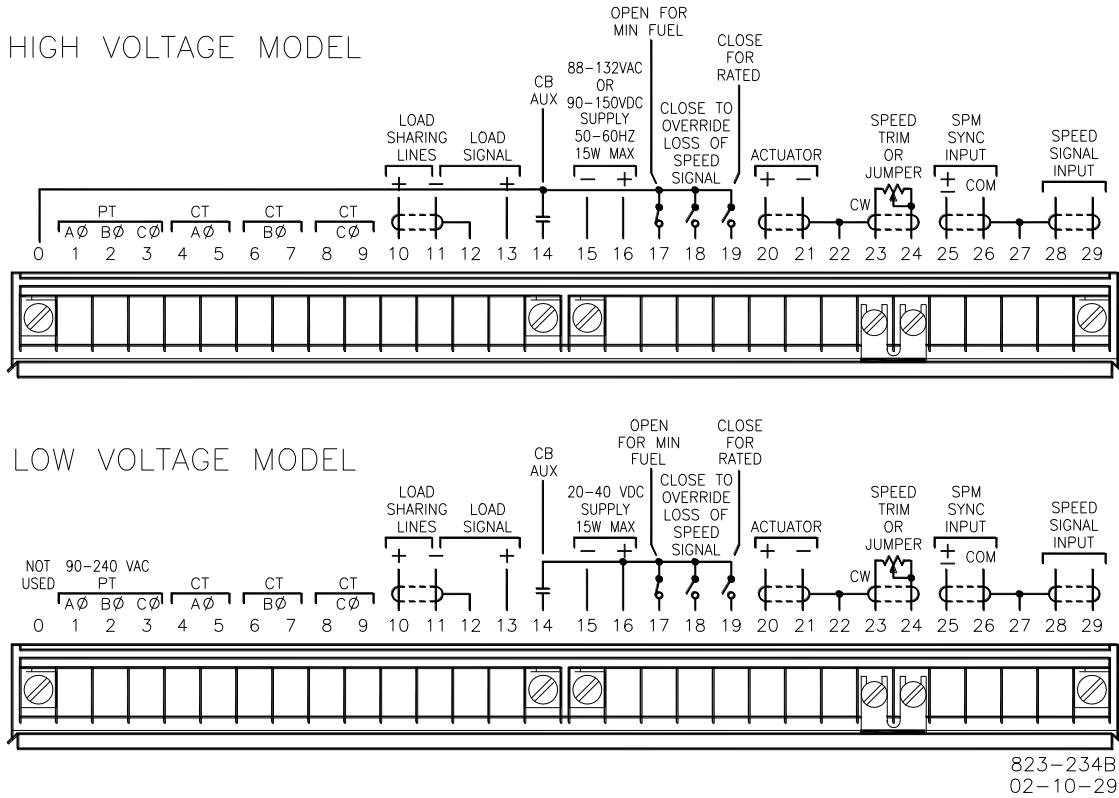

823-234B  
02-10-29

**NOTES**

- Terminal 0**—On high voltage models, this terminal provides +20 Vdc for input terminals 14, 17, 18, 19, and 30. On low voltage models, this terminal is not used.
- Terminal 14**—When contact is closed, control is in isochronous and the load sharing lines are active. When open, control is in droop and the load sharing lines are disabled.
- Terminal 16**—On low voltage models, this terminal provides a +dc source for input terminals 14, 17, 18, 19, and 30, and is the dc supply + connecting point. On high voltage models, this terminal is either one of the ac input terminals (on ac supply) or the dc + connecting point (on dc supply).
- Terminal 17**—A contact to drive the output to minimum fuel when required for shutdown.\* The jumper must *not* be used on high voltage models.
- Terminal 18**—A contact to override the failed speed protective circuit for start-up and start fuel setup calibration.
- Terminal 19**—A contact to accelerate from idle to rated speed when the contact is closed.
- Terminals 23 and 24**—An external means of remotely fine tuning the speed setting. It also may be used for manual synchronization or for loading the generator when operating in droop mode.
- Terminals 25 and 26**—Provide for use of an optional speed and phase matching (SPM) synchronizer. An SPM synchronizer automatically generates a signal to bias the speed of the prime mover of an off-line generator so that its frequency and phase match those of the bus.\*\*

\*—Do *not* use the minimum fuel contact option as part of any emergency stop sequence.

\*\*—See Woodward manual 82384, *SPM-A Synchronizer 9905-002*, for more information on the SPM-A.

Figure 4-3. Terminal Connections

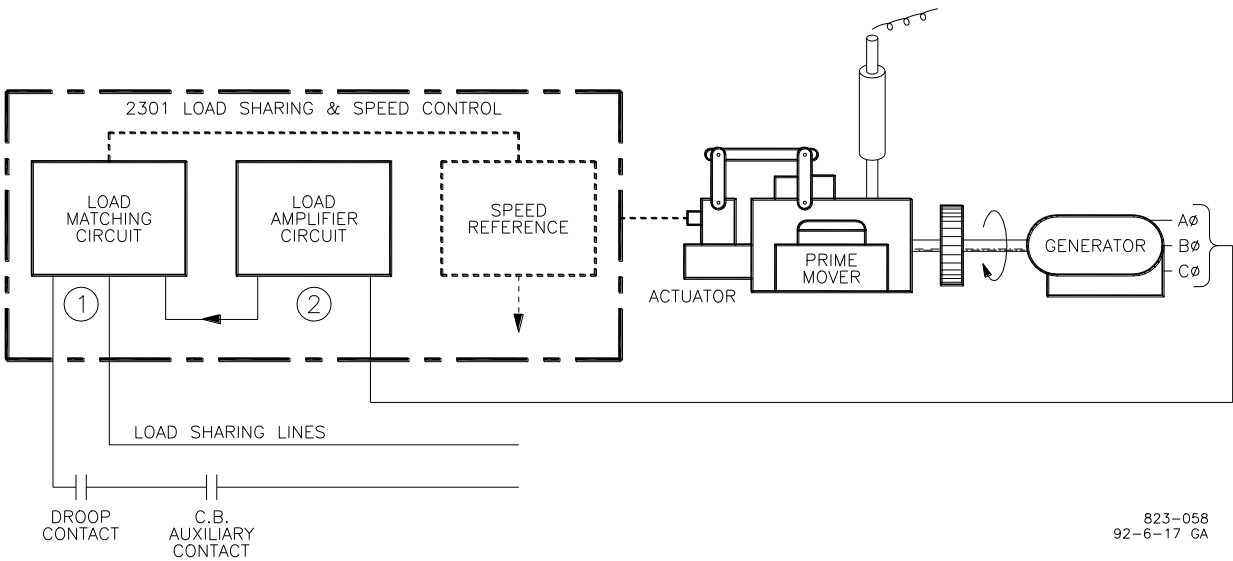

823-058  
92-6-17 GA

Figure 4-4. Paralleling System

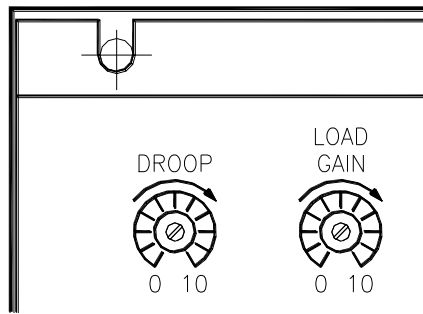

Figure 4-5. Paralleling Adjustments

As mentioned in the general information section, droop mode allows operation of a generator on an infinite bus or in parallel with other engine generator units using hydromechanical governors. In droop, speed changes as the load on the generator changes. An increase in load results in a decrease in speed. The amount of speed change or droop is expressed in percent, and is set by the DROOP potentiometer shown in Figure 4-5.

The 2301A Load Sharing and Speed Control is powered by a dc-dc isolated power supply, which allows operation over a wide voltage range without generating excessive heat. This isolation protects the system from interference caused by ground loops, particularly through the load-sharing lines, and allows load sharing with earlier models of Woodward load-sharing controls.

# Chapter 5. Troubleshooting

The following troubleshooting guide is an aid in isolating trouble to the control box, actuator, plant wiring, or elsewhere. Troubleshooting beyond this level is recommended ONLY when a complete facility for control testing is available.

<b>NOTICE</b>	<b>The control can be damaged with the wrong voltage. When replacing a control, check the power supply, battery, etc., for the correct voltage.</b>
---------------	---

## Troubleshooting Procedure

Table 5-1 is a general guide for isolating system problems. This guide assumes that the system wiring, soldering connections, switch and relay contacts, and input and output connections are correct and in good working order. Make the checks in the order indicated. Various system checks assume that the prior checks have been properly done.

<b>! WARNING</b>	<b>Be prepared to make an emergency shutdown when starting the engine, turbine, or other type of prime mover, to protect against runaway or overspeed with possible personal injury, loss of life, or property damage.</b>
------------------	--

Table 6-1. Troubleshooting

Symptom	Cause	Remedy
Prime mover will not start. Actuator not moving to start-fuel position.  <b>NOTE</b> —If the actuator moves to start position, a problem with the prime mover fuel supply is indicated.	Supply voltage polarity reversed (dc only), or no supply voltage.	Check for proper voltage from terminals 16 (+) to 15 (-). Reverse leads if polarity is incorrect (dc only).
	Actuator not responding to input signal from control.	If there is a voltage output at control terminals 20 (+) and 21 (-), but the actuator does not move, the wiring to the actuator should be checked for opens or shorts. With the EG3P actuator, remember that terminals C and D of the mating plug should be jumpered.  Make resistance checks at the actuator. Coil resistance on Woodward actuators is approximately 35 Ω. (Read with leads at T20 and T21 disconnected.)
	<div style="background-color: #006633; color: white; padding: 2px; display: inline-block;"><b>IMPORTANT</b></div> <i>The hydraulic actuator must have oil pressure and gear rotation to operate (respond).</i>	
	Start fuel limit set too low.	Turn start fuel limit clockwise until prime mover starts.
	Actuator or Linkage.	Check actuator and linkage for proper installation and operation. Problems may be oil supply, direction of rotation, insufficient drainage, linkage, worn actuator components, or improper adjustment.
No actuator voltage at terminals 20 and 21.	Check for shorted or grounded actuator leads by removing wires to terminals 20 and 21. Stop prime mover. Close the switch on terminal 18, short terminal 23 to 24. Check for 18 to 22 volts at terminals 20 and 21 for forward acting controls, and 0 to 1 volt for reverse acting controls.  Check for at least 1 Vrms at terminals 28 and 29, and at least 5% of the minimum rated speed frequency range.	

Symptom	Cause	Remedy
Prime mover will not start. Actuator not moving to start-fuel position. (cont.)	Speed setting too low on initial start.	Control may be the wrong speed range. Check speed sensor frequency versus control part number. Speed setting may be lower than cranking speed. Control should be set for rated speed. Increase RATED SPEED setting clockwise.  <b>NOTICE</b> <b>If adjusting RATED SPEED setting clockwise does not produce the correct output, return RATED SPEED setting to normal start position—full counterclockwise.</b>
	LOW IDLE SPEED setting may be set too low.	Adjust LOW IDLE SPEED potentiometer clockwise.
	Minimum Fuel contact open. See "Minimum Fuel Contact" in Chapter 2.	Check T 17. Minimum-fuel contact must be closed for normal operation. Check for 20 to 40 Vdc from terminal 17 (+) to 15 (-).
	Speed sensor signal not clearing failed speed signal circuit.	Check wiring for proper connection. Check shields for proper installation.  Speed sensor not spaced properly—check for at least 1.0 Vac at terminals 28 and 29 during cranking. If less than 1.0 Vac, magnetic pickup may be spaced too far from gear. Make sure there are no metal chips on end of pickup.  If no voltage is present, magnetic pickup may be open-circuited or shorted. Make resistance check with the leads disconnected from control. Should be about 100 to 300 $\Omega$ .  Failed speed-signal circuit may be disabled by connecting terminal 16 (or terminal 0 on high voltage controls) to terminal 18.  <b>WARNING</b> <b>Be prepared to make an emergency shutdown when starting the engine, turbine, or other type of prime mover, to protect against runaway or overspeed with possible personal injury, loss of life, or property damage.</b>
	Terminals 23 and 24 are open.	Verify that terminals 23 and 24 are jumpered if optional external speed trim is not used.
	Faulty speed trim potentiometer.	With power OFF, check speed trim potentiometer(s) with an ohmmeter.
	Faulty 2301A control.	Replace control.
Prime mover will not start (high-voltage control).	Common + source for contacts connected to terminals 14, 17, 18, and 19 taken from terminal 16 instead of from terminal 0.	Connect + source for these terminals to terminal 0, not 16.
Prime mover overspeeds only on starts.	Ramp adjustment.	Increase RAMP TIME (clockwise). This decreases acceleration rate (from low idle to rated).
	RATED SPEED setting too high.	Set RATED SPEED as described in Chapter 3.
	Amplifier adjustment.	Amplifier may be adjusted for sluggish operation, causing overspeed on start. Slowly adjust GAIN for fastest stable response. RESET may be adjusted too low, increase RESET setting.
	Determine if engine is malfunctioning.	Verify that fuel rack is not binding and linkage is properly adjusted. Determine if the fuel rack is quickly following the actuator input voltage. Check operation of overspeed protection device(s).

Symptom	Cause	Remedy
Prime mover overspeeds or causes excessive smoke only on starts.	Start Fuel Limit is inactive.	On power up, Fuel Limit can be bypassed if MPU signal clears in less than 1 second. Power up 2301A before cranking engine.
	2301A control.	If the control does not cut back the actuator voltage [T20 (+) and T21 (-)] until the speed setting is completely counterclockwise (or does not reduce fuel at any position), the 2301A control may be faulty, or may have the wrong speed range. If the voltage is cut back, look for a problem in the linkage or actuator.
Prime mover overspeeds after operating at rated speed for some time.	Prime mover.	Check for proper operation of prime-mover fuel system. If actuator moves toward minimum fuel during overspeed, problem is in fuel system.
	Magnetic pickup and 2301A control.	Check the magnetic-pickup output voltage at speeds above idle-at least 1.0 Vrms. If magnetic pickup should fail and the override-failed-speed-signal circuit is disabled, the 2301A control will call for maximum fuel.
	2301A control amplifier.	Control the prime mover manually at rated speed and adjust the RATED SPEED setting fully counterclockwise. If the output voltage is not zero, check for proper speed range switch adjustment as described in Chapter 2. If speed range is correct for the application, replace the control.
Prime mover has momentary speed change when adjusting GAIN.	GAIN adjustment made too quickly.	Make GAIN adjustment slowly. Small momentary speed changes when adjusting GAIN is normal.
Low speed is not regulated by LOW IDLE SPEED potentiometer.	<p style="text-align: center;"><b>IMPORTANT</b></p> <p><i>On carbureted prime movers, the minimum fuel stop rpm setting will vary with prime mover temperature. An improper cold setting may give interference with the LOW IDLE SPEED setting when the prime mover is hot.</i></p>	<p>The LOW IDLE SPEED setting may be below the minimum-fuel position of the actuator or prime-mover fuel stop. In this case, the output voltage to the actuator will be zero.</p> <p>The engine will be maintained at the minimum-fuel position by the actuator or the prime mover minimum-fuel stop. The conditions above indicate that the prime mover minimum-fuel position should be decreased by linkage adjustment (diesel engine) or low-idle set screw (gas engine), or the LOW IDLE SPEED setting should be raised. If the above action does not correct the problem, the 2301A control may be faulty.</p>
	LOW IDLE SPEED potentiometer.	If adjustment of the LOW IDLE SPEED potentiometer causes erratic behavior, replace the control.

Symptom	Cause	Remedy
Prime mover does not decelerate when Close for Rated contact is open.	Faulty Close for Rated contact.	Check Close for Rated contact. Remove wire from terminal 19. Prime mover should decelerate.
	LOW IDLE SPEED set fully clockwise ( <b><i>be careful not to overtorque the pot</i></b> ).	Turn LOW IDLE SPEED setting counterclockwise with terminal 19 open.
	2301A control ramp circuitry.	<p>A faulty Close for Rated contact may remain in the accelerate position with the contact open.</p> <p>If the Close for Rated contact is operative, loss of idle control may be due to a faulty circuit.</p> <p>In general, adjustment of LOW IDLE SPEED will vary the speed of the prime mover with the Close for Rated contact in the decelerate (open) position. Adjustment of LOW IDLE SPEED should not affect prime mover speed when the Close for Rated contact is closed.</p> <p style="text-align: center;"><b> WARNING</b></p> <p><b>The speed-setting controls have sufficient range to override the ramp and bring the prime mover speed up to rated while still in the low-idle mode (either by defect or switching). Therefore, a Close for Rated contact that is intermittent may cause the prime mover to overspeed if the RATED SPEED setting is adjusted for rated speed with T19 open.</b></p>
Prime mover will not stabilize at rated no load speed. The instability may occur at no load or it may vary with load. Control may be erratic.	2301A control.	Adjust GAIN, RESET, and ACTUATOR COMPENSATION as described in "Adjust for Stable Operation" and "Dynamic Adjustment" in Chapter 3.
	Speed setting controls.	If adjustment of external speed trim causes instability, check potentiometer with ohmmeter for erratic behavior (turn power off). Use non-lubricating electrical cleaner if necessary. If internal speed potentiometer is faulty, replace control.
	Improper linkage adjustment.	Make sure that actuator moves approximately 2/3 of its travel from no load to full load. Be sure linkage is linear on turbine, diesel, and fuel-injected prime movers. Be sure linkage is non-linear on carbureted prime movers. Refer to actuator manual for proper installation.

Symptom	Cause	Remedy
<p>Prime mover will not stabilize at rated no load speed. The instability may occur at no load or it may vary with load. Control may be erratic. (cont.)</p>	<p>Necessary external wires not properly shielded.</p> <p>Electrical noise, caused by wiring carrying an ac voltage, stray magnetic fields from transformers, etc., can be picked up by improperly shielded wire. Noise will cause instability if picked up by lines associated with the amplifier summing point such as external speed trim, paralleling lines, droop contact, magnetic pickup lines, and synchronizer input.</p>	<p>The following tests will isolate noise and interference.</p> <p style="text-align: center;"><b>NOTICE</b></p> <p><b>Do not perform these tests in other than single-unit operating configuration.</b></p> <p>Jumper terminal 19 to terminal 16 (terminal 0 on high voltage controls), and remove wires to the Close for Rated contact.</p> <p>Where an external speed trim is used, jumper terminals 23 and 24, and remove wires to the potentiometer.</p> <p style="text-align: center;"><b>WARNING</b></p> <p><b>Prime mover may overspeed if jumper is installed while running.</b></p> <p>Remove wires to terminals 10, 11, 12, 14, 25, and 26. Jumper 14 and 16.</p> <p>Remove the wires to the minimum-fuel contact at terminal 17.</p> <p>Verify that the switchgear frame, governor chassis, and prime mover have a common ground connection. Temporarily remove the battery-charger cables from the control battery system.</p> <p>If the prime-mover operation is significantly improved by the above modifications, replace the wiring one at a time to locate the source of the trouble.</p> <p>External wiring may require additional shielding or rerouting from high-current lines or components.</p> <p>(continued below)</p>
		<p>(cont.)</p> <p>If the problem cannot be resolved by the above checks, it will be necessary to remove the 2301A control from the switch-gear. Temporarily mount it next to the prime mover and connect only a battery, magnetic pickup, and actuator to the control (use a separate battery placed next to the prime mover). After starting the prime mover, place a small jumper wire across terminals 19 and 16 to cause the prime mover to accelerate to rated speed. If necessary, apply load to check stability.</p> <p>If stability occurs when the control is mounted next to the prime mover, return the control to the switchgear. Run new magnetic pickup, actuator, and battery power lines. Shield all wires to the control. Route all wires through conduit or an outer shield. Tie the outer shield to system ground at end opposite of the control.</p>
	<p>Prime mover may not be receiving fuel as called for by the actuator voltage.</p>	<p>Check actuator linkage to fuel controlling mechanism for any lost motion, binding, or excessive loading. Verify a steady fuel pressure of proper value.</p> <p>Check actuator per appropriate actuator manual.</p>

Symptom	Cause	Remedy
Prime mover will not stabilize at rated no load speed. The instability may occur at no load or it may vary with load. Control may be erratic. (cont.)	Prime mover not operating properly.	Prime mover may be causing speed variations. Control engine manually to determine if instability is in prime mover or governor control. Verify proper adjustment of fuel control linkage.
	Input voltage low.	Check supply voltage, It should be at least 20 Vdc on low voltage controls and 90 Vdc or 88 Vac on high voltage controls.
Speed-setting control does not regulate speed.	Faulty RATED SPEED or Speed Trim potentiometer.	Check by replacing Speed Trim with jumper and setting speed with main speed potentiometer.
Prime mover does not share load with other units.	Prime mover not receiving fuel as called for by the governor.	If voltage to actuator is maximum (minimum for reverse-acting), visually determine if actuator shaft is at maximum position. If it is not, an actuator problem is indicated, or the linkage or fuel system is restricted.
	Unequal speed settings.	Be sure that speed settings of all units at no load are identical.
	Unequal load-gain voltages.	With the prime mover operating in single unit configuration, LOAD GAIN must be set at 6.0 Vdc. See "Load Gain Adjustment" in Chapter 3.
	Circuit breaker auxiliary contact or droop contact is open.	Check auxiliary circuit breaker and droop contacts. Check for 18 to 40 Vdc from terminal 14 to 15 on low voltage controls.  <b>IMPORTANT</b> <i>High voltage controls can only be measured from terminal 14 to 18 if the close to override failed speed signal contact is not closed.</i>
	Improper load-sensing phasing.	Perform phasing procedure in Chapter 3.
	Circulating currents between generators.	Refer to appropriate voltage regulator manual.
Prime mover does not maintain constant speed (isochronous).	Actuator.	If actuator has a ballhead backup, verify that its hydraulic governor section, speed setting, and speed droop adjustments are properly set (see the applicable governor manual).
	Prime mover.	If droop occurs near the full-load point only, it is possible the prime mover is not producing the power called for by the fuel control, or is being overloaded. Either is indicated if the fuel control is at maximum position.

# Chapter 6.

## Product Support and Service Options

### Product Support Options

If you are experiencing problems with the installation, or unsatisfactory performance of a Woodward product, the following options are available:

1. Consult the troubleshooting guide in the manual.
2. Contact the **OE Manufacturer or Packager** of your system.
3. Contact the **Woodward Business Partner** serving your area.
4. Contact Woodward technical assistance via email ([EngineHelpDesk@Woodward.com](mailto:EngineHelpDesk@Woodward.com)) with detailed information on the product, application, and symptoms. Your email will be forwarded to an appropriate expert on the product and application to respond by telephone or return email.
5. If the issue cannot be resolved, you can select a further course of action to pursue based on the available services listed in this chapter.

**OEM or Packager Support:** Many Woodward controls and control devices are installed into the equipment system and programmed by an Original Equipment Manufacturer (OEM) or Equipment Packager at their factory. In some cases, the programming is password-protected by the OEM or packager, and they are the best source for product service and support. Warranty service for Woodward products shipped with an equipment system should also be handled through the OEM or Packager. Please review your equipment system documentation for details.

**Woodward Business Partner Support:** Woodward works with and supports a global network of independent business partners whose mission is to serve the users of Woodward controls, as described here:

- A **Full-Service Distributor** has the primary responsibility for sales, service, system integration solutions, technical desk support, and aftermarket marketing of standard Woodward products within a specific geographic area and market segment.
- An **Authorized Independent Service Facility (AISF)** provides authorized service that includes repairs, repair parts, and warranty service on Woodward's behalf. Service (not new unit sales) is an AISF's primary mission.
- A **Recognized Engine Retrofitter (RER)** is an independent company that does retrofits and upgrades on reciprocating gas engines and dual-fuel conversions, and can provide the full line of Woodward systems and components for the retrofits and overhauls, emission compliance upgrades, long term service contracts, emergency repairs, etc.

A current list of Woodward Business Partners is available at [www.woodward.com/directory](http://www.woodward.com/directory).

### Product Service Options

Depending on the type of product, the following options for servicing Woodward products may be available through your local Full-Service Distributor or the OEM or Packager of the equipment system.

- Replacement/Exchange (24-hour service)
- Flat Rate Repair
- Flat Rate Remanufacture

**Replacement/Exchange:** Replacement/Exchange is a premium program designed for the user who is in need of immediate service. It allows you to request and receive a like-new replacement unit in minimum time (usually within 24 hours of the request), providing a suitable unit is available at the time of the request, thereby minimizing costly downtime.

This option allows you to call your Full-Service Distributor in the event of an unexpected outage, or in advance of a scheduled outage, to request a replacement control unit. If the unit is available at the time of the call, it can usually be shipped out within 24 hours. You replace your field control unit with the like-new replacement and return the field unit to the Full-Service Distributor.

**Flat Rate Repair:** Flat Rate Repair is available for many of the standard mechanical products and some of the electronic products in the field. This program offers you repair service for your products with the advantage of knowing in advance what the cost will be.

**Flat Rate Remanufacture:** Flat Rate Remanufacture is very similar to the Flat Rate Repair option, with the exception that the unit will be returned to you in “like-new” condition. This option is applicable to mechanical products only.

## Returning Equipment for Repair

If a control (or any part of an electronic control) is to be returned for repair, please contact your Full-Service Distributor in advance to obtain Return Authorization and shipping instructions.

When shipping the item(s), attach a tag with the following information:

- return number;
- name and location where the control is installed;
- name and phone number of contact person;
- complete Woodward part number(s) and serial number(s);
- description of the problem;
- instructions describing the desired type of repair.

## Packing a Control

Use the following materials when returning a complete control:

- protective caps on any connectors;
- antistatic protective bags on all electronic modules;
- packing materials that will not damage the surface of the unit;
- at least 100 mm (4 inches) of tightly packed, industry-approved packing material;
- a packing carton with double walls;
- a strong tape around the outside of the carton for increased strength.

### **NOTICE**

To prevent damage to electronic components caused by improper handling, read and observe the precautions in Woodward manual 82715, *Guide for Handling and Protection of Electronic Controls, Printed Circuit Boards, and Modules.*

## Replacement Parts

When ordering replacement parts for controls, include the following information:

- the part number(s) (XXXX-XXXX) that is on the enclosure nameplate;
- the unit serial number, which is also on the nameplate.

## Engineering Services

Woodward's Full-Service Distributors offer various Engineering Services for our products. For these services, you can contact the Distributor by telephone or by email.

- Technical Support
- Product Training
- Field Service

**Technical Support** is available from your equipment system supplier, your local Full-Service Distributor, or from many of Woodward's worldwide locations, depending upon the product and application. This service can assist you with technical questions or problem solving during the normal business hours of the Woodward location you contact.

**Product Training** is available as standard classes at many Distributor locations. Customized classes are also available, which can be tailored to your needs and held at one of our Distributor locations or at your site. This training, conducted by experienced personnel, will assure that you will be able to maintain system reliability and availability.

**Field Service** engineering on-site support is available, depending on the product and location, from one of our Full-Service Distributors. The field engineers are experienced both on Woodward products as well as on much of the non-Woodward equipment with which our products interface.

For information on these services, please contact one of the Full-Service Distributors listed at [www.woodward.com/directory](http://www.woodward.com/directory).

## Contacting Woodward's Support Organization

For the name of your nearest Woodward Full-Service Distributor or service facility, please consult our worldwide directory published at [www.woodward.com/directory](http://www.woodward.com/directory).

You can also contact the Woodward Customer Service Department at one of the following Woodward facilities to obtain the address and phone number of the nearest facility at which you can obtain information and service.

Products Used In Electrical Power Systems		Products Used In Engine Systems		Products Used In Industrial Turbomachinery Systems	
<u>Facility</u>	<u>Phone Number</u>	<u>Facility</u>	<u>Phone Number</u>	<u>Facility</u>	<u>Phone Number</u>
Brazil	+55 (19) 3708 4800	Brazil	+55 (19) 3708 4800	Brazil	+55 (19) 3708 4800
China	+86 (512) 6762 6727	China	+86 (512) 6762 6727	China	+86 (512) 6762 6727
Germany:		Germany	+49 (711) 78954-510	India	+91 (129) 4097100
Kempen	+49 (0) 21 52 14 51	India	+91 (129) 4097100	Japan	+81 (43) 213-2191
Stuttgart	+49 (711) 78954-510	Japan	+81 (43) 213-2191	Korea	+82 (51) 636-7080
India	+91 (129) 4097100	Korea	+82 (51) 636-7080	The Netherlands	+31 (23) 5661111
Japan	+81 (43) 213-2191	The Netherlands	+31 (23) 5661111	Poland	+48 12 295 13 00
Korea	+82 (51) 636-7080	United States	+1 (970) 482-5811	United States	+1 (970) 482-5811
Poland	+48 12 295 13 00				
United States	+1 (970) 482-5811				

For the most current product support and contact information, please visit our website directory at [www.woodward.com/directory](http://www.woodward.com/directory).

## Technical Assistance

If you need to contact technical assistance, you will need to provide the following information. Please write it down here before contacting the Engine OEM, the Packager, a Woodward Business Partner, or the Woodward factory:

### General

Your Name \_\_\_\_\_

Site Location \_\_\_\_\_

Phone Number \_\_\_\_\_

Fax Number \_\_\_\_\_

---

### Prime Mover Information

Manufacturer \_\_\_\_\_

Engine Model Number \_\_\_\_\_

Number of Cylinders \_\_\_\_\_

Type of Fuel (gas, gaseous, diesel,  
dual-fuel, etc.) \_\_\_\_\_

Power Output Rating \_\_\_\_\_

Application (power generation, marine,  
etc.) \_\_\_\_\_

---

### Control/Governor Information

#### Control/Governor #1

Woodward Part Number & Rev. Letter \_\_\_\_\_

Control Description or Governor Type \_\_\_\_\_

Serial Number \_\_\_\_\_

---

#### Control/Governor #2

Woodward Part Number & Rev. Letter \_\_\_\_\_

Control Description or Governor Type \_\_\_\_\_

Serial Number \_\_\_\_\_

---

#### Control/Governor #3

Woodward Part Number & Rev. Letter \_\_\_\_\_

Control Description or Governor Type \_\_\_\_\_

Serial Number \_\_\_\_\_

---

### Symptoms

Description \_\_\_\_\_

\_\_\_\_\_

\_\_\_\_\_

*If you have an electronic or programmable control, please have the adjustment setting positions or the menu settings written down and with you at the time of the call.*

---

# Revision History

---

**Changes in Revision U—**

- Updated Compliance listings and Declaration of Conformity

**Changes in Revision T—**

- Revision advanced to coordinate with new installation sheet.

**Changes in Revision R—**

- Updated resistance value in Installation Checkout Procedure, Grounds Check (page 13)
- Updated Compliance listings and Declaration

# Declarations

## EU DECLARATION OF CONFORMITY

**EU DoC No.:** 00131-04-CE-02-03  
**Manufacturer's Name:** WOODWARD INC.  
**Manufacturer's Contact Address:** 1041 Woodward Way  
 Fort Collins, CO 80524 USA  
**Model Name(s)/Number(s):** 2301A Load-Sharing Speed Control  
**The object of the declaration described above is in conformity with the following relevant Union harmonization legislation:** Directive 2014/30/EU of the European Parliament and of the Council of 26 February 2014 on the harmonization of the laws of the Member States relating to electromagnetic compatibility (EMC)  
**Applicable Standards:** Directive 2014/35/EU on the harmonisation of the laws of the Member States relating to the making available on the market of electrical equipment designed for use within certain voltage limits  
 EN61000-6-4, 2007/A1:2011: EMC Part 6-4: Generic Standards - Emissions for Industrial Environments  
 EN61000-6-2, 2005: EMC Part 6-2: Generic Standards - Immunity for Industrial Environments  
 EN50178:1997 - Electronic Equipment for Use in Power Installations  
**Last two digits of the year in which the CE marking was affixed for the first time:** 02

This declaration of conformity is issued under the sole responsibility of the manufacturer  
 We, the undersigned, hereby declare that the equipment specified above conforms to the above Directive(s).

MANUFACTURER



Signature

Christopher Perkins

Full Name

Engineering Manager

Position

Woodward, Fort Collins, CO, USA

Place

Date

01-JUN-2016

5-09-1183 Rev 26

THIS PAGE INTENTIONALLY LEFT BLANK

